



Enapter has set out to redefine the electrolyser world

Enapter has set out to redefine the world of electrolyser and become a major player within the megatrend hydrogen. The company offers a patented AEM Electrolyser, which is claimed to be more cost-effective and efficient than competitive technologies. The key to success lies in the standardized modular design of Enapter's smaller electrolysers, which can be combined to form a large system as required. The race in the still very young market has only begun and Enapter is preparing with a significant expansion of production. Based on this, we forecast a tremendous growth for Enapter (revenue CAGR of 169% until FY 2025e). By their nature, earnings are expected to remain depressed until FY 2023e. We initiate coverage on Enapter with a Buy rating and a target price of EUR 34.

Easy to handle, standardized and scalable electrolysers

Enapter offers standardized AEM electrolysers of smaller scale. However, due to its modularity, the electrolysers can be built up like Lego modules to a very large power plant in MW size. This scalability is very crucial for Enapter's business model. Unlike very large individual systems, the modular design allows the advantages of mass production to be achieved. Further, the electrolyser is less vulnerable and can continue to operate, even if single modules are to fail.

The Enapter Campus in Saerbeck

Enapter plans a massive expansion of its electrolyser production capacity from currently around 100 units/month to 10,000 units/months. For this purpose, a new production facility will be built in Saerbeck, Germany until the end of 2022. This is going to be the only production plant for electrolysers of this size on the market. Of the expected EUR 100m investment, Enapter intends to finance around EUR 30m via a new capital increase in 2021.

EURm	2019	2020	2021e	2022e	2023e
Revenues	1	2	9	42	130
EBITDA	(1)	(3)	(9)	(7)	7
EBIT	(2)	(4)	(11)	(12)	3
EPS	(0.48)	(1.23)	(0.47)	(0.54)	0.01
EPS adj	-	-	-	-	-
DPS	-	-	-	-	-
EV/EBITDA	-	-	-	-	-
EV/EBIT	-	-	-	-	-
P/E adj	-	-	-	-	-
P/B	0.93	8.90	14.07	19.65	19.50
ROE (%)	-	-	-	-	0.8
Div yield (%)	-	-	-	-	-
Net debt	(1)	(4)	(12)	83	101

Source: Pareto

Target price (EUR)	34
Share price (EUR)	27

Forecast changes			
%	2021e	2022e	2023e
Revenues	NM	NM	NM
EBITDA	NM	NM	NM
EBIT adj	NM	NM	NM
EPS reported	NM	NM	NM
EPS adj	NM	NM	NM

Source: Pareto

Ticker	H2O, H2O
Sector	Renewables & Clean Tech
Shares fully diluted (m)	24.4
Market cap (EURm)	651
Net debt (EURm)	-12
Minority interests (EURm)	0
Enterprise value 21e (EURm)	640
Free float (%)	19

Performance



Source: Factset

Pareto Securities AS has been paid by the issuer to produce this research report. This material is considered by Pareto Securities to qualify as an acceptable minor non-monetary benefit according to the EU MIFID 2 directive.

Analysts

Zafer Rüzgar
+49 69 58997 412, zafer.ruezgar@paretosec.com

Table of contents

Investment Case	3
Company profile	4
Electrolyser – Key component for green hydrogen	6
Product portfolio at a glance	9
AEM Multicore Electrolyser	11
On the way to mass production	12
Cost of producing green hydrogen	13
Major production targets from competitors	16
Hydrogen – more than a megatrend	17
Financials	19
Construction of our P&L forecasts	19
Capital increase ahead	23
Valuation	25
DCF valuation	25
Peer group model	26
Appendix	27
Management	27
Shareholder structure	28
Overview of competitors	29

Investment Case

Enapter produces and sells patented **AEM (anion exchange membrane) electrolyzers**. An electrolyser is the elementary component for producing hydrogen from renewable sources. It is a device, which splits water into hydrogen and oxygen by using electricity, in particular generated from renewable sources, and therefore does not cause any CO₂ emission. The hydrogen market and consequently Enapter as well are still in a very early stage of their development.

While the large majority of its competitors are offering significantly more well-known electrolyser technologies such as PEM and Alkaline, Enapter as a newcomer takes a new path with its AEM electrolyzers. According to Enapter, its **AEM technology combines the best out of the two worlds**. It offers an efficiency as high as a PEM electrolyser but is cost competitive and easy to handle like an Alkaline electrolyser. We believe, with the growing hydrogen market and increasing applications of the AEMs, Enapter's competitive edge will become more visible.

Hydrogen will play a key role in order to **decarbonize the energy industry** and strongly contribute to achieve the ambitious **climate targets of the countries** worldwide. Due to its versatile applications, it is expected that demand for hydrogen will jump to >500 Mt by 2050e from currently <100 Mt and account for up to 25% of the global energy demand by then. In order to serve the expected demand, it will require an electrolyser capacity of 3,600 GW, compared to a currently installed capacity of around 200 MW. We can observe how countries around the globe are currently running massive support programs to build up their own national hydrogen industry.

Enapter's business model is based on a **rapid build-up of mass production**. In addition to the ongoing decline of renewable energy costs and technological advances, economies of scale will be decisive for the market breakthrough of hydrogen. Based on electrolyser costs of EUR 800-3,000 per kW, the production of green hydrogen is 2-3x higher than the production of grey hydrogen. Enapter targets to bring down electrolyser costs to EUR 500 per kW by 2025e. Unlike its competitors, Enapter does not offer single, large scale plants, but **standardized modules of electrolyzers (plug and play)**, which will play out its cost advantages with significantly increasing production figures. Individually, Enapter's electrolyzers are of lower power range (<5 kW), however, can be combined to form large systems, comparable to solar PV modules, which can be combined to GW scale power plants.

Enapter is in the process of setting up mass production of its electrolyzers. For this purpose, a **new production facility is to be built in Saerbeck, Germany** with an expected investment volume of EUR 100m. With this new facility, current **production rate of approx. 100 units/month is targeted to increase to 10,000 units/month** from 2023e onwards. Our estimates are based on Enapter's production ramp-up. We forecast Enapter to surpass the EUR 100m revenue threshold in FY 2023e and achieve break-even at EBITDA level, consistently with the expectations of the company.

Our valuation of Enapter is based on a **DCF model as well as a peer group model**. The DCF model is appropriate to reflect the long-term prospects of the company as well as of the hydrogen market. However, it should be kept in mind, that it will likely take some years before Enapter will achieve sizeable revenues and related earnings. Due to the fact of a significant number of listed companies with a very similar business model as Enapter and a strong focus on the hydrogen market, the peer group comparison provides in our view a good basis for a relative valuation. From the equally weighted average of both methods, we derive a **target price of EUR 34.00** per share, which implies an **upside potential of 27%**.

Company profile

Enapter (H2O GY) is set to become a major player in the emerging hydrogen market with its patented electrolyser solutions. Following the acquisition of the electrolyser technology company Heliocentris Italy SRL, who did an asset deal in 2014 with ACTA SPA, Enapter was started in 2017 by the entrepreneur and current CEO Sebastian-Justus Schmidt. At this time, ACTA was already a leading supplier of AEM (Anion Exchange Membrane) electrolysers. Enapter has developed the technology into an end market mature product ready for mass production. Core technology of its electrolysers is based on its patented AEM technology, which is claimed to have significant advantages compared to other electrolysers, as it does not require expensive materials such as titanium and has a simple construction structure.

An electrolyser is the elementary component for producing hydrogen from renewable sources. It is a device, which splits water into hydrogen and oxygen by using electricity. Assuming this electricity is generated from renewable sources, the produced hydrogen is green and has a zero-carbon footprint. The only emission from the process is oxygen.

Exhibit 1: Where to use an electrolyser in the hydrogen value chain

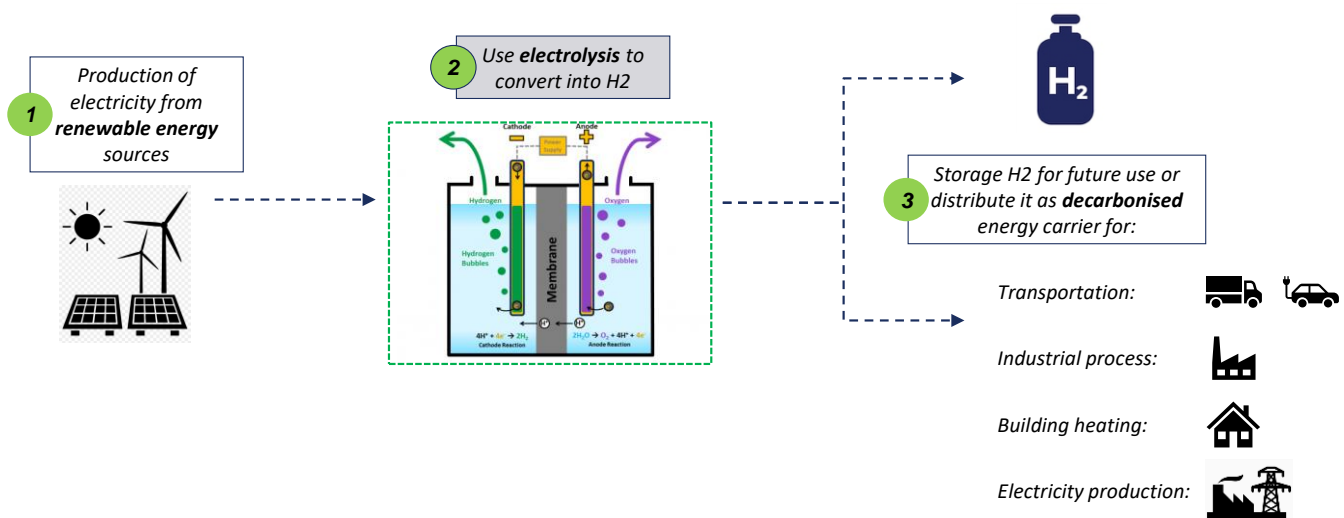

Source: Pareto Securities Research

The diagram above illustrates how the usage of an electrolyser becomes a multiplier for the application of hydrogen in different sectors. The “Power-to-X” process stands for the conversion of electricity to other energy carriers, through the use of hydrogen, which is produced in the electrolysis process.

Enapter offers standardized, scalable, and resilient electrolysers. The company’s modularity and mass production approach differ quite fundamentally from the large scale, individual and project-related otherwise systems offered in the industry.

In doing so, the main idea is to offer solutions in huge quantities and at more economic conditions. Further cost reductions will be necessary in the future to make hydrogen more competitive and establish it as an energy carrier. Enapter’s scalable technology can be compared to that of photovoltaics, in which several thousand PV modules are connected to a large power plant. If an individual electrolyser fails, the efficiency of the entire plant is hardly affected and can be replayed during operation.

Enapter’s most recent electrolyser, which is still in the development phase, the EL Model T/X is powered by a 2.2 kW stack module. The same stack module can be combined into a megawatt class electrolyser (size of a 40 feet container). The container, Enapter calls it the AEM Multicore, can in turn be stacked to achieve a multi megawatt system. Enapter also offers a smart Energy Management System Toolkit for its customers for simple control and monitoring of AEM electrolysers of any size.

Enapter, which currently employs 132 people, is set to start mass production in 2022 at their new plant factory The Enapter Campus, Saerbeck Germany. The targeted production capacity in the first stage is 10,000 units per month. So far, the company has sold 1,609 electrolysers to 166 customers around the world.

Enapter’s shares are listed in the regulated market of the Frankfurt and Hamburg stock exchange. The listing took place through a reverse merger, where the majority takeover of the then insolvent and listed S&O Beteiligungen AG was acquired by the BluGreen Company Limited, Hong Kong. The majority owner of BluGreen is Enapter’s CEO Sebastian-Justus Schmidt with a 96.7% stake.

Exhibit 2: Group structure

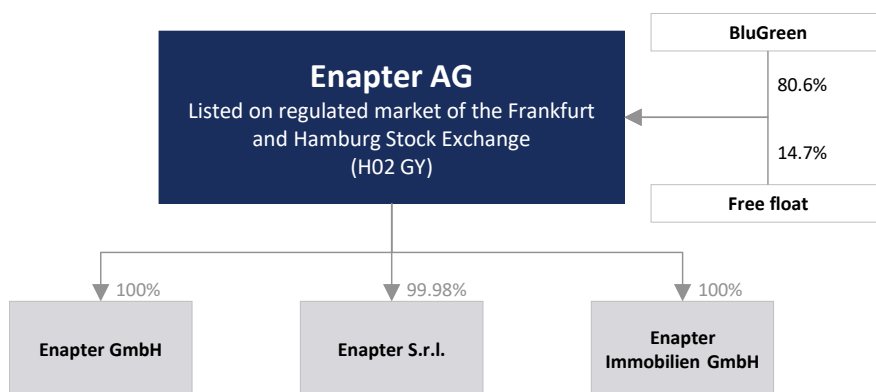

Source: Enapter, Pareto Securities Research

Enapter GmbH is located in Berlin and is the beginnings of the operational unit in Germany. Currently, there takes no production place in the unit.

Enapter S.r.l. is based in Pisa and has essentially been an R&D site. At the end of 2019, Enapter started series production here and in the meantime expanded the site.

Enapter Immobilien GmbH was founded in February 2021 in conjunction with the planned construction of the new production facility in Saerbeck, Germany.

Electrolyser – Key component for green hydrogen

In 2017, with the acquisition of Heliocentris Italy SRL, which did an asset deal with the company Acta SPA, Enapter has secured access to a patent-protected technology in the future market of hydrogen. Electrolysers are crucial components to produce emission free hydrogen. The production process itself is called electrolysis.

In simplified terms, in an Enapter electrolyser an electrochemical reaction is used to separate water (H₂O) into hydrogen (H₂) and oxygen (O). This process takes place in a cell. Several cells bundled together make a stack, which in turn is the heart of an electrolyser. The cell consists of a polymer electrolyte membrane (AEM – anion exchange membrane) and specially designed low-cost electrodes, the anode (positive charge) and cathode (negative charge). While the anode side is filled with water, the cathode side is dry and operates under pressure with up to 35 bar. From the anode, water (H₂O) is transported through the membrane to the cathode side. This is when pure hydrogen is formed at the cathode under very dry conditions. What remains is a negative composition of water and oxygen (OH⁻), which migrates back to the anode side and will be emitted from there as pure oxygen. According to Enapter, with the usage of the company’s auxiliary dryer module, the produced hydrogen achieves 99.999% purity. Enapter’s unique technology is the design and the operation of these cells.

Exhibit 3: How does an Enapter AEM Electrolyser works?

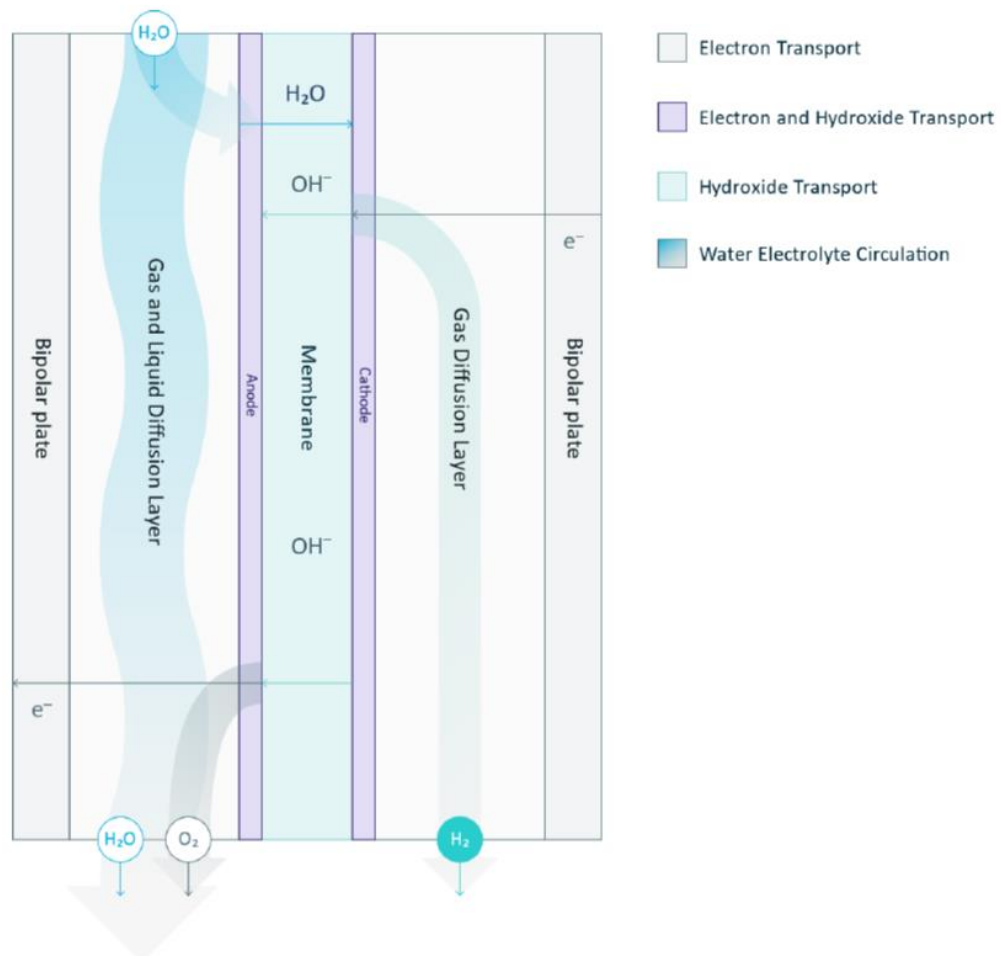

Source: Enapter, Pareto Securities Research

In the currently still very small spread of electrolyzers, there are two processes that are most frequently used, the alkaline (AE) and proton exchange membrane (PEM). In the following section, we look into the technologies available in the market and make a comparison, as it relates to technological advancements and costs competitiveness.

Alkaline electrolyser (AE)

The traditional alkaline electrolysis is the most established and commercialized process, which is mainly used in the chemical and refining industry. In the alkaline electrolyser, the electrodes are operating in a liquid alkaline solution, where electricity splits water into hydrogen and oxygen. Due to the fact, that in the alkaline electrolysis process less expensive materials are used, it has a cost advantage in comparison to the PEM electrolyser technology. Another advantage is the very long service life of alkaline electrolyzers (> 30 years). The essential disadvantage is the response time, which should be a problem when using electricity from renewable sources.

Proton exchange membrane electrolyser (PEM)

The PEM technology was first introduced by GE in 1960s to overcome some disadvantages of AE process. Here, water reacts at the anode into oxygen and hydrogen, which flow through the PEM to the cathode, where it will be finally converted into hydrogen gas. The PEM electrolyzers are relatively small and therefore more attractive for decentralized solutions and refueling stations. However, given the fact, that the electrolyte is a special material (platinum, iridium) it is more expensive and less efficient. Due to the harsh and high acidic environment, the process requires robust and expensive materials. In particular the cost issue offers limited economies of scale, when it comes to large installations. Further disadvantages compared to AE are the shorter lifetime of PEMs and that they are still less mature. However, PEMs have a very short response time with low base load requirements, which makes them very suitable for wind and solar.

Exhibit 4: Comparison of electrolyser technologies

	PEM	Alkaline	AEM - Enapter	SOEC
Operating conditions				
LVH* efficiency (in %)	57.5	60.3	60.8	45-55
Necessary minimum power (in %)	5	15	c. 1	n.a.
Output pressure (bar)	<70	<30	<35	<10
Temperature (°C)	50-80	70-90	40-60	700-850
Cost parameters				
Water consumption (l/kg)	15	15	12	n.a.
System lifetime (in years)	20	20	20	n.a.
Stack lifetime (in hours)	40,000	80,000	35,000	<20,000
CAPEX (EUR/kW)	c. 1,000	c. 800	c. 300	>2,000
OPEX (% of CAPEX)	2	2	3	n.a.
Flexibility				
Start-up time (in min)	<5	<10	<5	n.a.
Ramp-up/Ramp-down (per second)	100%	0.2-20%	100%	n.a.
Shut-down time	seconds	<10	seconds	n.a.
Water purity requirement	<1 µS/cm	<1 µS/cm	<20 µS/cm	n.a.
Footprint (m ² /MW)	37	60	30	n.a.

*LVH: lower heating value

Source: IRENA, Enapter, Pareto Securities Research

Solid oxide electrolyser cells (SOEC)

The SOE technology is not yet commercialized. A less costly ceramic material is used as the electrolyte that generates hydrogen. However, the process needs a heat source and therefore operates at much higher temperatures (700-800°C), which reduces the lifetime. The most important feature is that the SOE

technology is currently mainly suitable for kW scale installations and has challenges with regard to MW/GW installations.

Currently, the AE technology is the most advanced and widespread technology. The higher investment costs and the lower efficiency are the most common disadvantages of the PEMs. According to the management, Enapter is offering with its patented AEM technology the best of both worlds – AEM electrolyzers with the efficiency of the PEMs but at the low cost of the AE electrolyzers. For example, instead of expensive titanium for its bipolar plates, Enapter uses much cheaper and widely available materials such as steel. This is possible, as the AEM process works in a less corrosive alkaline environment. While AE electrolyzers do not need titanium, the handling of an AEM Electrolyser is much easier and safer compared to the AE rival. The Enapter electrolyser uses a mild alkaline solution, which is much less corrosive and caustic (1% vs typically 20% KOH).

In scientific literature, difficulties with the mechanical and chemical stability of its membrane are sometimes still attributed to AEM technology, which Enapter, however, could not confirm. According to Enapter, this problem has mostly occurred in the research and development of fuel cells, where the membranes can easily dry out. According to Enapter, in the AEM electrolysis process membranes are always sufficiently wet, thus avoiding chemical instabilities. According to Enapter, even after several thousand hours of operations, the mechanical and chemical properties of their membranes remain unchanged.

Given the fact that the share of renewable sources in the electricity production steadily increases and green hydrogen requires renewable sources, the flexibility of the electrolyser will be of significant importance, in our view. Variable renewable energy from wind or solar will need electrolyzers that can be ramped-up and down very quickly.

According to IRENA (International Renewable Energy Agency) there are currently more than 30 companies worldwide developing electrolyzers of the above-mentioned technologies. We believe that in addition to the cost aspect, the ramp-up of industrial serial production will be decisive for the commercial success of any technology. Before we discuss the cost factor in detail, we take a closer look to Enapter's product portfolio.

Product portfolio at a glance

According to the management, Enapter has sold >1,500 electrolyzers to 182 customers in 38 countries worldwide. The overall capacity of the Enapter’s electrolyzers in the market is around 4 MW. The company currently sells its electrolyser EL 2.1 which was introduced in February 2020. The electrolyser with the dimensions of 482x594x310mm corresponds to the size of about a microwave and weighs 55kg. With a power consumption of 2.4 kW, the EL 2.1 is able to produce 1.0785 kg of hydrogen per day. More importantly, the price of the EL 2.1 of EUR 9,000 (EUR 3,750 per kW) has decreased by about 18% compared to its predecessor EL 2.0 (EUR 11,000 or EUR 4,580 per kW).

Exhibit 5: Enapter’s electrolyser – from yesterday to tomorrow



Source: Enapter, Pareto Securities Research

From the still young history, we can observe that the company has short product cycles. In addition to improving performance and increasing lifetime, the main target is to further reduce costs. It is expected that the next stage in development of the electrolyser, the EL Model 4 will be reduced in price.

Unlike most of their competitors, Enapter follows the approach of developing and producing all major components in-house. This naturally results in a capital-intensive business model, compared to competitors who have important components or even their electrolyzers produced by contract manufacturers. However, due to the high vertical integration, Enapter can better control critical processes and supply chains. This includes, above all, the production of the chemical products, such as the electrodes and the membrane. The chemical products are integrated in a cell, several of which together form a stack. As already mentioned in this report, the stack is considered the heart of the electrolyser. At the end of Enapter’s value chain is the final assembly of the electrolyser.

According to Enapter, the AEM stack module is the foundation of Enapter’s product platform. Both the stack and the electrolyser are standardized products, which are targeted to be produced in hundred thousand and soon millions of units. Integrator can stack single AEM Electrolyser in a range of up to hundreds of kW like a Lego modular system. However, AEM stack modules in large numbers can power a MW AEM electrolyser – the AEM Multicore. This modularized, plug-and-play architecture makes the whole system less vulnerable for technical faults

as single stacks can be replaced during operation without having a shutdown of the entire system.

Exhibit 6: Platform-based approach – from kilowatt to megawatt

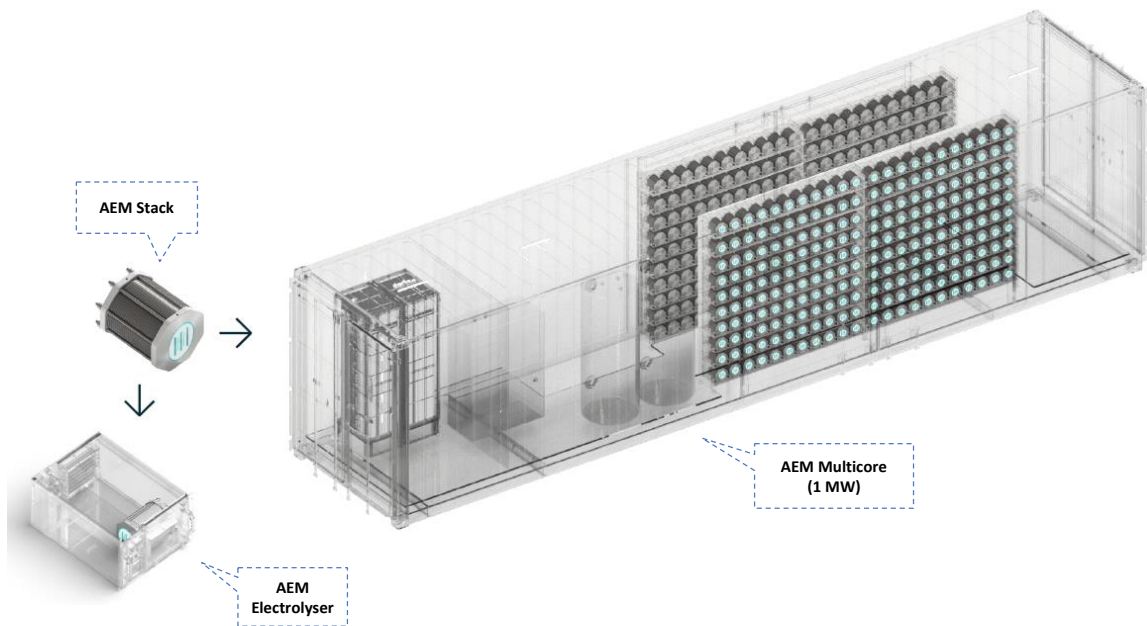

Source: Enapter, Pareto Securities Research

This modular approach allows for much shorter development cycles. More importantly, the system requires to go into mass production of stacks and electrolysers, which are expected to lead to a reduction of development and production costs. We believe that Enapter’s competitiveness will be determined by the company’s ability to produce stacks in high volumes that are also showing improving efficiency.

Enapter draws parallels to its approach with the solar industry. Individual solar modules produced in very large quantities can be combined to form solar parks in GW capacity sizes. Short development cycles and mass production have led to significant cost reductions for solar modules. Furthermore, the development has led to a shift in energy generation from very large centralized solutions to decentralized units.

Exhibit 7: What does Enapter has common with the solar industry?



Source: Enapter, Pareto Securities Research

Besides the modularity, the scalability of Enapter’s electrolysers is an important differentiator. Depending on the capacity requirements of its customers, modules can be added in MW scale. This makes the electrolyser flexible and universally applicable.

In order to control a smooth hydrogen production flow, Enapter has developed a proprietary open software. The software is an elementary part of the electrolyser. However, it is far more than that and offers operators an energy management system toolkit that can be used to control and monitor the electrolyser plus any connected energy devices.

AEM Multicore Electrolyser

The AEM Multicore is Enapter's first electrolyser at MW scale. The container-sized electrolyser consists of more than 400 AEM stacks. It is also possible to connect several Multicore electrolysers together to form a multi MW solution. The expected hydrogen production of the Multicore is 210 Nm³/h or 9.4 kg/h.

Exhibit 8: AEM Multicore – The solution for MW scale

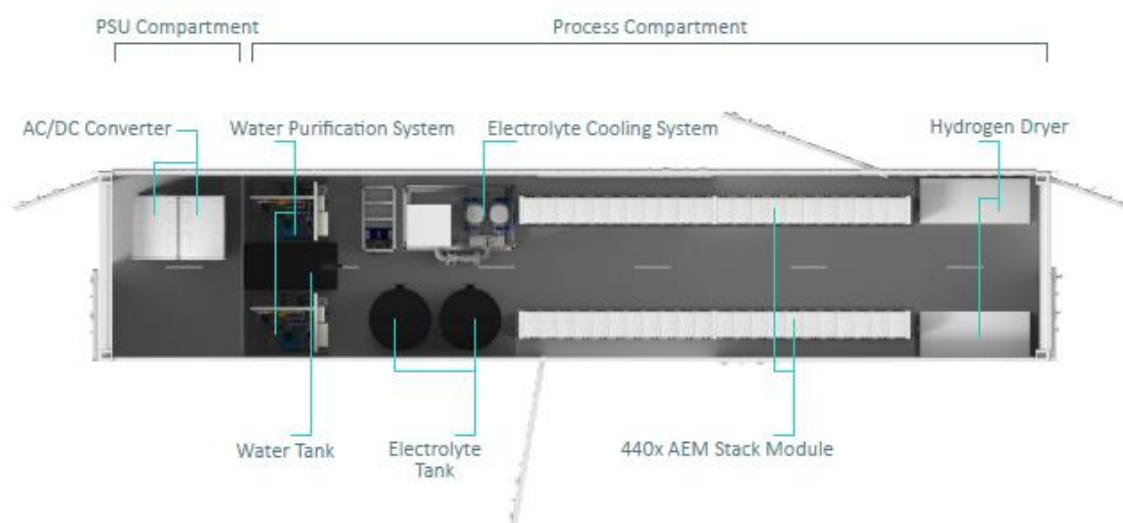

Source: Enapter, Pareto Securities Research

The AEM Multicore is designed to use the same stacks as Enapter's AEM Electrolyser. Using more than 400 stacks allows for the system to be flexible and robust without a single point of failure. The expected lifetime of the stacks is currently 35,000 hours, but according to Enapter could be on par with PEM electrolysers once stacks are mass produced. Due to the modular build, the stacks can be replaced if needed even during operation and the AEM Multicore can continue to operate and produce hydrogen. We will go into more detail on the cost comparison later in this report. The large number of stacks gives the operator of the electrolyser also the flexibility to operate only the number of stacks needed to supply the available amount of electricity. For electrolysers powered by renewable energy, it is hardly possible to assume 100% capacity utilization. Thus, the run-time efficiency can always be optimized.

At this point, it should be mentioned that Enapter has consciously decided to develop smaller electrolysers than most competitors for the time being. The expectation is that smaller electrolysers can be introduced to the market faster than the GW scale plants. The worldwide distribution of standardized products via external distributors is to be established faster. The megaprojects in the field of hydrogen currently in planning stage in the GW scale are rather manageable in their numbers. Given the fact, that the majority of the solar and wind parks are significantly smaller than 1 GW, the market needs mass-produced solutions rather than industrial plants, in our view. Enapter has decided to be a product driven company, rather than being a project-driven one.

On the way to mass production

Enapter has started its serial production in 2019 in its facility in Pisa, Italy. The site in Italy, which actually operated as an R&D facility since 2017, was expanded to include a production facility. In December 2020, Enapter acquired an additional building, which is used for the scale up of chemical and stack production. In 2020, the monthly production rate amounted to 20-50 electrolysers, implying a production capacity of 1 MW on average.

Exhibit 9: Our assumptions for monthly production rates in units

Exhibit 10: ... and in MW

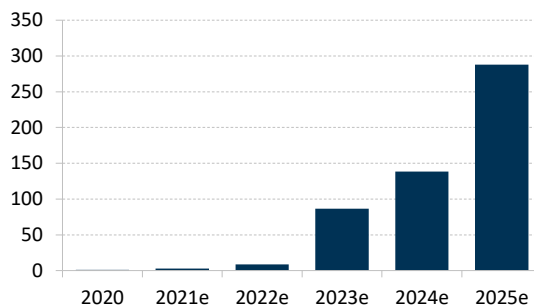
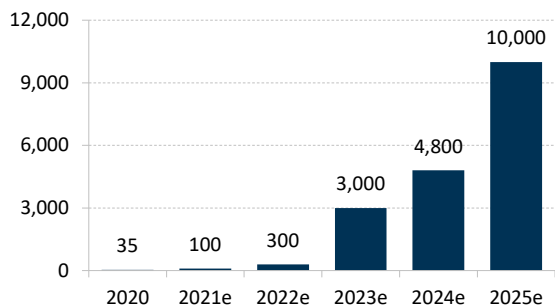

Source: Enapter, Pareto Securities Research

Source: Enapter, Pareto Securities Research

Enapter plans a massive expansion of its production capacity. Monthly production rate, which are currently at around 100 units per month, should increase up to 10,000 units per months from FY 2025e onwards. The current delivered figures of 604 units in the first six months in 2021 show that Enapter is already at a monthly production rate of around 100 units.

The expected annual production figures of >100,000 units exceed many times that of the competitors. Given the smaller scale of Enapter’s electrolysers (< 5kW), the company has to connect several hundred smaller ones, in order to achieve MW solutions. This is an essential part of the company’s strategy, as Enapter believes that significant cost savings can only be achieved with very large volumes of standardized electrolysers.

In order to be able to implement the aggressive production ramp-up, Enapter plans to establish a new production facility in Saerbeck, Germany. The construction of the new facility, which also will be Enapter’s new headquarter, is scheduled to begin in Q3 2021. The expected costs are EUR 100m. From 2023, Enapter targets here a monthly production of 10,000 units, which corresponds to annual capacity of around 300 MW.

Exhibit 11: The Enapter Campus in Saerbeck



Source: Enapter, Pareto Securities Research

Cost of producing green hydrogen

The production costs of green hydrogen of EUR 5-8/kg is still expensive and not competitive. This is 2-3 times higher than the production cost of grey hydrogen (produced by fossil fuels but contains CO₂ emission). From today's point of view, there are three major costs drivers for the production of green hydrogen:

1. CAPEX for the electrolyser
2. Utilization factor of the electrolyser
3. Cost of green electricity produced within the process

We believe that the third factor is largely exogenous and less influenceable by the hydrogen industry. However, as already seen in past years, electricity costs generated by renewable sources has significantly declined. According to calculations of IRENA, LCOE (levelized cost of electricity) of PV power projects fell by almost 90% since 2010. Due to ongoing R&D efforts and technology improvements, costs are expected to fall steadily, making renewable investments more affordable. The price decline could even be much more pronounced than originally expected. According to BloombergNEF, its current forecast for the LCOE of solar PV is 40% lower by 2050 than two years ago estimated.

Exhibit 12: Global weighted average LCOE, USD/kWh

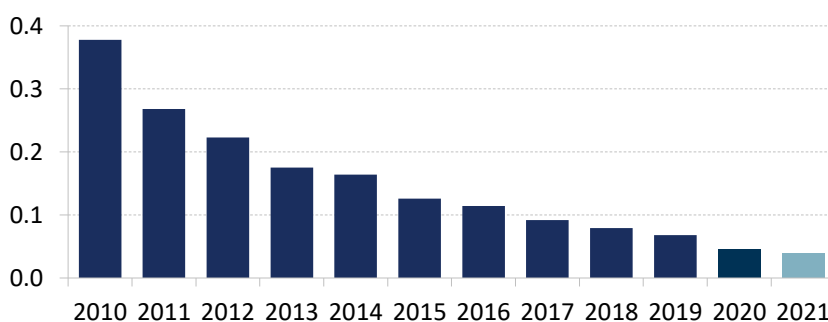

Source: IRENA, Pareto Securities Research

The utilization rate depends on the availability of renewable energy resources. A higher utilization rate means that investment costs will have a smaller portion in the overall per kg hydrogen production costs. Taking into account the expected increasing share of renewable sources, the utilization rate is also expected to increase further. Given the fact that green hydrogen plants are not expected to be connected to the grid and electricity generated from solar and wind are volatile by nature, a 100% utilization seems rather unlikely.

The cost of the electrolyser currently accounts for up to 50% of the total investment. According to market research institutes, Capex for electrolyser (PEM) is expected to decline from current levels of USD 1,000-1,800/kW to around USD 200-300/kW by the end of the decade. In addition to technological advances, the expected ramp-up of the mass production by electrolyser manufacturers and the industrialization of the supply chain will be the main factors contributing to the expected decline in costs.

We believe that for hydrogen to be competitive as an energy carrier in the future, the cost development of the electrolyser will be very crucial. Therefore, we would like to take a closer look at the expected cost development of the electrolysers in the following section.

Exhibit 13: Breakdown of green hydrogen production cost

Cost of producing hydrogen	
Electricity consumption in kWh per kg H2	53.39
Electricity costs, EUR/kWh	0.06
Electricity costs, EUR/kg	3.20
Electrolyser Capex, EUR/kW	1,200
Load factor 20%, in h per annum	1,752
Produced H2 in kg	32.81
Capex in EUR per kg H2	36.57
Lifetime in years	20
Annual costs, EUR/kg H2	1.83
Opex, 3 % of Capex	0.05
Capital costs, 8%	0.15
Annual O&M	0.20
Hydrogen costs, EUR/kg H2	5.23

Source: Pareto Securities Research

According to the Hydrogen Council, hydrogen produced at costs of below EUR 3 per kg is expected to be competitive with conventional energy sources, in particular for applications in the mobility sector. This target is likely to be achieved in the second half of the decade. The main trigger for the expected decline in production cost is the price of the electrolyser. The International Energy Agency predicts that cost of producing hydrogen could decline by 30% from current levels until 2030, due to further falling costs for renewable energy and economies of scale in the hydrogen production process. The following examples calculated for Enapter's current and future electrolysers illustrate that the targeted cost reduction will be triggered by the electrolyser costs.

Exhibit 14: Breakdown of green hydrogen production cost for Enapter's electrolysers

Cost of producing hydrogen	EL 2.1 (2021)	EL T (2023)	Multicore (2025)
Electricity consumption in kWh per kg H2	53.39	53.39	53.39
Electricity costs, EUR/kWh	0.06	0.06	0.06
Electricity costs, EUR/kg	3.20	3.20	3.20
Electrolyser Capex, EUR/kW	3,750	1,042	546
Load factor 20%, in h per annum	1,752	1,752	1,752
Produced H2 in kg	32.81	32.81	32.81
Capex in EUR per kg H2	114.28	31.75	16.63
Lifetime in years	17.12	19.98	19.98
Annual costs, EUR/kg H2	6.67	1.59	0.83
Opex, 3 % of Capex	0.20	0.05	0.04
Capital costs, 8%	0.53	0.13	0.07
Annual O&M	0.73	0.17	0.11
Hydrogen costs, EUR/kg H2	10.61	4.97	4.14

Calculated lifetime for EL T and Multicore: 35,000 hours (<20 years) at 20% load factor

Opex for Multicore: 5% of Capex

Source: Enapter, Pareto Securities Research

Alkaline and AEM electrolyzers are currently the most economical solutions. As already mentioned in this report, the PEM is the most expensive one. The reason for the competitive disadvantage of the PEMs lies in the bipolar plants (account for 53% of the stack costs), the key components of the stack, which are made from expensive materials like titanium. Even if cost savings are to be expected in the future due to the expected economies of scale, it is questionable from our point of view whether these components can be installed cost-effectively. Presumably, PEM suppliers have to develop alternative technological solutions, in order to be cost competitive, which however is not likely to be easy. Within the AE electrolyzer, the manufacturing of the diaphragm as well as the electrode packages is the most expensive part. It seems, that these items can be realized at more favourable conditions with increasing production volumes.

Exhibit 15: Cost breakdown for a 1 MW Electrolyser

Electrolyser & key components	EUR/kw	Electrolyser & key components	EUR/kw	Electrolyser & key components	EUR/kw
PEM Electrolyser	1,200	AE Electrolyser	800	AEM Electrolyser	1,000
Balance of Plant	55%	Balance of Plant	55%	Balance of Plant	70%
o/w Power Supply	50%	o/w Power Supply	50%	o/w Power Supply	19%
Stack components	45%	Stack components	45%	Stack components	30%
o/w Bipolar Plates	53%	o/w Diaphragm/Electrodes	57%	o/w Membrane electrode at	57%
	660		440		700
	330		220		133
	540		360		300
	286		205		171

Source: Enapter, IRENA, Pareto Securities Research

Our gathered cost breakdown in the megawatt class illustrates that the cost advantage of Enapter's AEM Multicore lies in the stack components as well as in the power supply costs. From today's point of view, the greatest cost savings in the AEM Electrolyser can be achieved in the balance of plant section. This is where the cost potentials are hidden. Unlike competitors who offers electrolyzers in the MW scale, Enapter's electrolyzers are of a lower power range and must accordingly be manufactured in very large quantities (in the example above >400 electrolyzers for the AEM Multicore). The costs of the balance of plant components will be significantly reduced in the context of the mass production. We have to keep in mind, that Enapter was able to reduce production costs since 2017 by 60%, without having set up a proper automatic production. For the next generation of electrolyzers, Enapter targets to bring down the price to EUR 1,000/kW by 2023 (EUR 500/kW by 2025e), which implies a further cost reduction of c.70%. However, these will then be manufactured in the new production facility as part of the serial production.

Since the majority of today's installed electrolyzers are rather in the demonstration and testing phase, we will see significant technological improvements in the years to come. The expected mass production will also significantly contribute to the overall competitiveness of the solution. We believe, Enapter has an advantage here, as the company targets to produce a vast majority of key components in-house and is thus in the driver seat. In addition to the expected cost savings, the greatest progress in improvement is likely to be in the lifetime of the stacks. We can observe, that for all electrolyser types the targeted stack lifetime is around or even above 100,000 hours, which would imply 11-12 years in theory if the plant would be in operation for 24h per day.

Exhibit 16: Cost targets of some competitors

Company	Type of electrolyser	Announced mid to long-term targets
McPhy	AE	EUR 1.5-2/kg by 2030
Nel Hydrogen	AE and PEM	USD 1.5/kg by 2025
Aker Clean Hydrogen	Developer and operator	EUR 500/kW by 2025 from EUR 1,300/kW
ITM	PEM	EUR 500/kW by 2025 from EUR 800/kW
McPhy	AE	EUR 300/kW by 2030 from EUR 700/kW

Source: Company, Pareto Securities Research

Major production targets from competitors

Together with the declining costs of renewable sources, improved and more efficient processes the expected massive ramp-up in electrolyser production will be essential for the expected decrease in cost. A good comparison here is the solar and wind industry, where industrial mass production has only ensured competitive prices. However, at the beginning of the introduction, the industry was built up with various government support measures. We currently see a number of states trying to build a national hydrogen industry with concrete supporting measures and targets.

While current installed electrolyser capacity is around 200 MW, the European Union targets within its hydrogen strategy an installed capacity of 40 GW by 2030. In order to achieve this ambitious goal, the industry needs to build up enormous production capacities. According to BloombergNEF the electrolyser global manufacturing capacity will reach around 3 GW by the end of 2021, from around 100 MW/year in the past years.

Exhibit 17: Electrolyser capacity targets set by countries

Countries	by 2030
European Union	40 GW
o/w France	6.5 GW
o/w Germany	5 GW
by 2040: 10 GW	10 GW
o/w Italy	5 GW
o/w Spain	4 GW
o/w The Netherlands	3.5 GW
o/w Portugal	2.3 GW
o/w Poland	2 GW
UK	10 GW
China	70-80 GW
USA	40 GW
Australia	30 GW
Chile	25 GW
Japan	15 GW

Source: Irena, Pareto Securities Research

In the previous sections, we had already outlined the production targets of Enapter. In the new production plant to be build, Enapter aims to achieve an annual production capacity of 200 MW from 2023. From there, ramping up capacities can be achieved efficiently and with potential new investments production capacity can reach 3-4 GW in 2025 according to Enapter. With these numbers, Enapter would sit at the upper end of the range compared to the targets of its competitors.

Exhibit 18: Electrolyser capacity targets set by some competitors

Company	Current	Target
Green Hydrogen Systems	<70 MW/year	1,000 MW/year by 2021
McPhy		<300 MW/year by 2022
Nel Hydrogen	80 MW/year	500 MW/year to 2,000 MW/year
Iberlyzer		200 MW/year by 2023
ITM	50 MW/year	300 MW to 1,000 MW/year
Plug Power		500 MW/year by 2024
ThyssenKrupp		1,000 MW/year
Enapter	10 MW/year	200 MW/year by 2023

Source: Irena, Pareto Securities Research

Hydrogen – more than a megatrend

In the last sections, we have dealt in detail with the electrolyser, the most important equipment for the production of green hydrogen. We discussed the fact, that costs for important components like electrolysers have to come down significantly in order to make the product hydrogen competitive. However, it first needs an impetus to get the market rolling and to be able to generate demand at all that can absorb the targeted increase in production capacity. This impetus currently is coming from governmental efforts and support across the globe. In this section, we want to look at the hydrogen market as a whole, try to outline the reasons for the expected demand as well as the drivers for the market.

In view of its eco-friendly properties and versatile application possibilities, it is expected that hydrogen will play a central role in the decarbonization of the energy industry and make a very significant contribution to limit global temperature rise to 1.5C. The energy sector is responsible for about c.40% of global CO₂ emissions today, mainly related to fossil fuel power generation. According to a report of the Hydrogen Council, global demand for hydrogen is forecasted to increase tenfold from currently around 90 Mt (million tonnes) to more than 500 Mt 2050. While today hydrogen is mainly used as a basic material for oil refining and producing fertilizers, it is expected that it will account for up to 25% of the global energy demand by 2050. The expected development of hydrogen demand until 2050 implies a growth CAGR of around 6%, which is very encouraging, if we take into account the very long period under review.

Exhibit 19: Global hydrogen demand in Mt

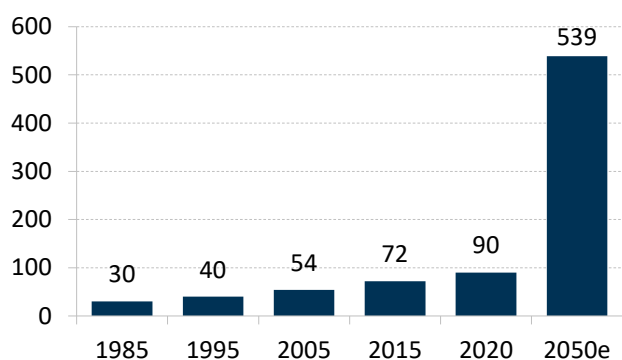

Source: IEA, IRENA, Pareto Securities Research

Exhibit 20: Hydrogen production by energy sources

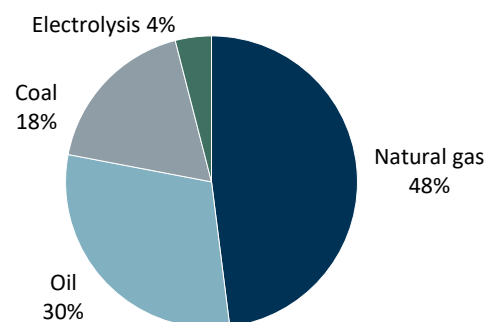

Source: Hydrogen Council, Pareto Securities Research

Today, only c.4% of hydrogen is produced by electrolysis and the predominantly portion is based on fossil fuels, resulting in a massive CO₂ emission of 830Mt/year (corresponding to the emission of Indonesia and UK). However, if the current demand for hydrogen has to be produced purely from electricity, the amount of electricity required would be equivalent to the entire electricity consumption of the EU.

In order to serve this demand, global electrolyser capacity is expected to increase to 800 GW in 2030 and then to 3,600 GW in 2050, according to estimates of IEA.

Like electricity, hydrogen is not an energy source but an energy carrier. That means it can be produced by various energy sources like CO₂ intensive fossil fuels but also by emission-free electricity gained by renewable energies sources. Hydrogen can be converted back to electricity but also to other energy sources, allowing a much broader and resilient energy mix with less dependency from single sources. Furthermore, due to its high energy density, hydrogen can be stored over extended period and transported in a flexible way, like conventional energy sources. The ability to store it makes hydrogen base-load capable and

help to overcome disruptions and outages in the power supply. It is particularly suitable in conjunction with renewable sources that can only provide electricity intermittently due to weather conditions.

From today's perspective, the transportation industry is expected to be the largest consumer of hydrogen with an estimated share of c.30%, followed by industrial feedstock and industrial energy.

Regardless of the enormous potential, the hydrogen market faces major challenges before the market maturity can be reached. We have explained in detail in the last sections about the currently still very high production costs and the lacking industrial production capacities. As already mentioned, the scale up of technology will be an important trigger for the market development. In addition, also the ongoing decline in renewable costs, which has a high portion in the overall production cost, will make hydrogen more affordable.

However, we believe that in the short term, a major push for the market will come from global governments, as these will strive to meet their ambitious climate change targets. As we have seen in the case of the development of the renewable energy sources, which also had to rely on political support in early stage, the hydrogen market will face massive support from governments across the globe. In order to set up a competitive a national hydrogen industry, some massive governmental support programs are on the way.

Exhibit 21: Massive funding by major countries

Countries	Committed funding
Germany	up to EUR 9bn by 2030
Spain	up to EUR 9bn by 2030
France	up to EUR 7bn by 2030
Portugal	c. EUR 1bn by 2030
Australia	up to AUD 800m by 2030

Source: IRENA, Pareto Securities Research

Financials

Enapter has a very short company history, which is heavily impacted by product developments and the beginnings of pre-serial production. The lack of a market maturity and sufficient orders have had a corresponding effect on the company's sales development. Consequently, an extrapolation from the historical development is therefore not very meaningful. However, it should be mentioned, that our estimates are subject to some uncertainties, as of today, it is impossible to estimate which technologies will prevail with customers. In addition, the future development of the hydrogen market is strongly dependent on political will, which may weaken unexpectedly, at least in certain areas.

Revenue development in H1 2021 was still at low level and earnings continued to be in the red, as can be seen in the following exhibition. It must be noted that pandemic related delays prevented even higher revenues. We assume, that these delays may have resulted in a revenue shortfall of around EUR 1m. In the first half of 2021e Enapter delivered 604 electrolyzers. Current order on hand resulted in an order backlog of EUR 12.3m, of which EUR 6m is to be booked in FY 2022e.

Exhibit 22: Review H1 2021

EUR m	Actual			Enapter's guidance	
	H1 2021	H1 2020	yoy	FY 2021e	FY 2022e
Order intake	6.3	-			
Revenues	2.0	0.6	217.8%	9.2	44.8
EBITDA	-3.6	-1.6	nm	-7.5	-7.0
EBITDA margin	neg.	neg.	nm	neg.	neg.
EBIT	-3.9	-1.8	nm		-8.7
EBIT margin	neg.	neg.	nm		
Net income	-4.0	-1.8	nm	-8.3	

Source: Enapter, Pareto Securities Research

Construction of our P&L forecasts

Our revenue model is based on a price quantity calculation. Given the fact, that the market is still in its infancy, it is hardly possible to forecast volume figures based on market expectations. Therefore, our revenue estimates are very much geared to Enapter's planned production ramp-up. In an initial phase, we assume production rate to grow from currently 100 units per month to up to 400 units by end of FY 2022e. With the expected inauguration of the new production facility in Q3/Q4 2022e, we assume a significant ram-up in production rates from FY 2023e onwards. During the same period, we forecast EUR/kW costs for electrolyser to decline towards EUR 500 for the MW scale AEM Multicore Electrolyser and towards EUR 800 per kW for the smaller scale electrolyzers.

In addition to the pure sale of electrolyzers, we assume that Enapter will also sell stacks and other components (e.g. membrane) to third parties. We assume that this business could account for up to 10% of total revenues.

Enapter is committed to confidentiality and does not name its customers. In our view, one possible reason for this is that certain customers distribute Enapter's electrolyzers as a white label product under their own name. For example, Toshiba Energy offers electrolyser on its website, which are very comparable to Enapter's electrolyser due to product characteristics. In the corresponding

datasheet, Toshiba states that they use an AEM electrolyzers. Given the fact, that we are not aware of an AEM Electrolyser developed by Toshiba, one can assume, that they use Enapter’s electrolyzers. We therefore do not exclude the possibility that Enapter has such business relationships that the company cannot report.

Exhibit 23: Key assumptions for our revenue estimates

		FY 2021e	FY 2022e	FY 2023e	FY 2024e	FY 2025e
Electrolyser price, average	EUR/kW	3,750	3,000	1,439	1,131	747
Units produced	per year	810	5,100	34,200	72,600	143,200
EL 2.1		810	0	0	0	0
EL 4.0		0	5,100	0	0	0
EL T		0	0	30,000	60,000	118,000
Multicore		0	0	10	30	60

Source: Enapter, Pareto Securities Research

Based on the above-mentioned assumptions, we estimate a revenue CAGR of 169% until FY 2025e, resulting in absolute revenue figures of EUR 294m.

Exhibit 24: Expected revenue development (EURm)

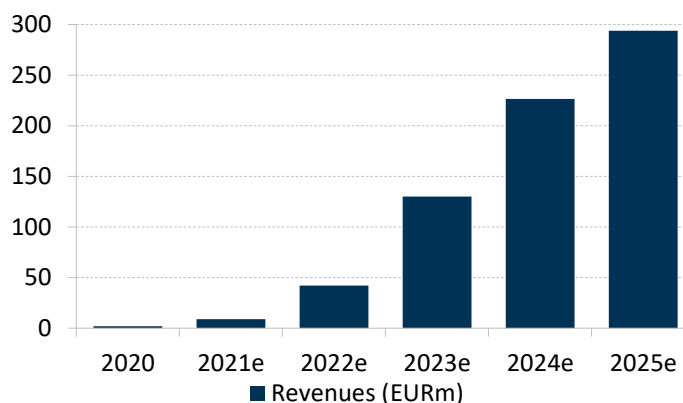

Source: Enapter, Pareto Securities Research

In our mid-term estimates, we expect gross margin to improve towards 35%. As Enapter is in a transition from pre-series production to mass production, we expect significant savings in purchasing conditions and production processes in the coming years. In our model, we assume a learning curve rate of 20%. This should result in Enapter achieving a gross margin of around 35% on a production volume of >100,000 units, which is in our model likely from FY 2025e onwards. A learning rate of 15% for example, would accordingly result in a lower margin (c.23%) being achieved for the same production volume. It is clear, that the sales prices per kW will drop in the years to come. However, it must be taken into account, that with increasing production volume, the purchase prices will also drop at least equally. We consider a gross margin of around 35% to be justified for a company with this technological background.

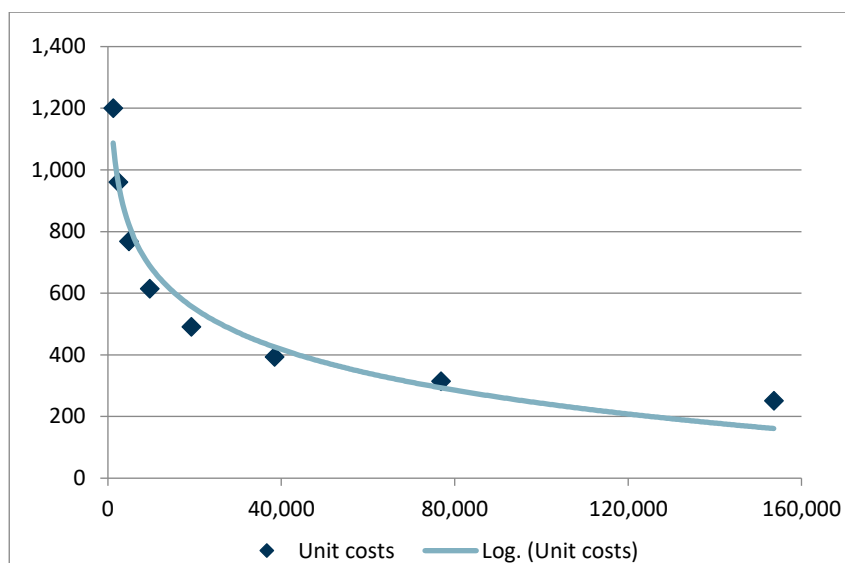
Exhibit 25: Assumed learning curve of 20% for electrolyser production

Source: Pareto Securities Research

In the course of the expected ramp-up of mass production, it is also worth looking at personnel costs. We expect the number of employees to increase significantly in accordance with the production ramp-up, especially from 2022/23 onwards, and that Enapter will employ more than 500 people. For the FY 2025e, we forecast personnel costs to be at around 11% of revenues, which might seem to be high at first glance. However, it should be noted that Enapter strives to produce as many components as possible itself. We do not rule out that our assumptions could change as the company makes progress in the production process once the lines are up and running or with increasing automation share. In our estimates for personnel costs, we have considered an annual cost inflation of 3.5%.

Exhibit 26: Development of staff and personnel costs

		FY 2019	FY 2020	FY 2021e	FY 2022e	FY 2023e	FY 2024e	FY 2025e
Employees		46	81	180	270	405	486	510
Personnel expenses	EURm	-1.8	-3.4	-7.2	-13.1	-20.6	-28.2	-32.6
Cost per employee	EUR	-79,425	-52,851	-55,494	-58,269	-61,182	-63,323	-65,540

Source: Enapter, Pareto Securities Research

A similar dynamic development is expected for other operating expenses, which should increase from currently EUR 2.4m to EUR 22m in FY 2025e, or to around c.8% of revenues. Going forwards, we would expect the cost ratio to remain at this level as Enapter will have higher sales and marketing expenses, which are expected to compensate for scale effects in the cost components.

On the back of the above-mentioned assumptions, we expect Enapter to reach break-even at EBITDA level from FY 2023e onwards. Our EBITDA estimate for FY 2025e of EUR 52.5m implies an EBITDA margin of c.18%. From today's point of view, we would be cautious with EBITDA margin expectations of >20% as there are many moving parts regarding growth and profitability that are difficult to predict at this stage.

Exhibit 27: Expected EBITDA development (EURm)

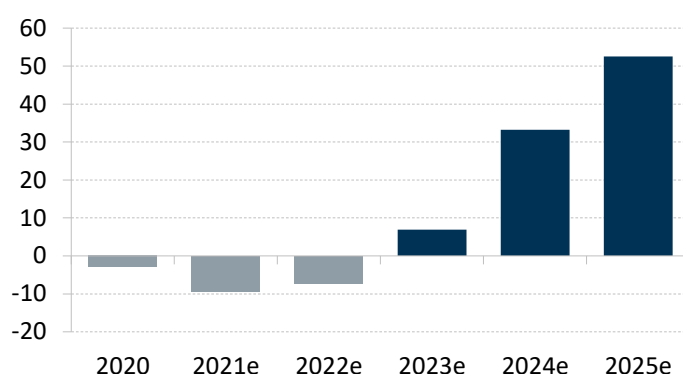

Source: Enapter, Pareto Securities Research

Our D&A assumptions are linked to Enapter's major investment project, the Enapter Campus. Taking into account the related CAPEX of around EUR 100m in the next two years, D&A should increase significantly.

Due to Enapter's tax loss carryforwards of around EUR 13m (thereof EUR 3.4m abroad) and the expected losses in the near term, we do not consider any substantial tax payments in our mid-term estimates.

As a consequence of the executed capital increase in March 2021 and the highly likely further capital increases, number of shares will increase further and lead to a dilution of EPS. We calculate with a weighted average of outstanding shares of 24.351m.

Exhibit 28: P&L at a glance

EUR m	2020	2021e	2022e	2023e	2024e	2025e
Revenue	2.1	8.7	42.2	129.9	226.5	293.7
% yoy		322.6%	382.7%	207.6%	74.4%	29.7%
Cost of materials	-2.3	-7.9	-29.6	-89.6	-149.5	-190.9
in % of revenues	-112%	-90%	-70%	-69%	-66%	-65%
Personel expenses	-3.4	-7.2	-13.1	-20.6	-28.2	-32.6
in % of revenues	145%	92%	44%	23%	19%	17%
Other operating expenses	-2.4	-6.0	-10.3	-16.4	-19.7	-22.1
in % of revenues	71%	83%	78%	80%	70%	68%
EBITDA	-2.9	-9.3	-7.3	6.9	33.2	52.5
EBITDA margin	-141%	-107%	-17%	5%	15%	18%
Depreciation & Amortization	-0.6	-1.5	-4.5	-4.4	-4.7	-4.6
EBIT	-3.5	-10.8	-11.8	2.5	28.5	47.9
EBIT margin	-171%	-124%	-28%	2%	13%	16%
Financial result	0.0	0.0	-1.4	-2.3	-3.0	-3.0
EBT	-3.6	-10.8	-13.1	0.3	25.5	44.9
EBT margin	154%	138%	44%	0%	-17%	-24%
Taxes	0.0	0.0	0.0	0.0	0.0	0.0
Net income	-3.6	-10.8	-13.1	0.3	25.5	44.9
Net income margin	-172%	-124%	-31%	0%	11%	15%
EPS	-1.23	-0.47	-0.54	0.01	1.05	1.84

Source: Enapter, Pareto Securities Research

Capital increase ahead

In March 2021, Enapter carried out a capital increase, raising EUR 18.3m at EUR per share (+832,000 shares). According to the management, the cash proceed should be enough to finance the company’s operational activities and in particular working capital for the next 12 months.

Enapter will require further funds for the planned construction of Enapter Campus. Construction begin is scheduled for Q3/Q4 2021 and is expected to be finalized in the second half of 2022.

Exhibit 29: Sources and use of proceeds

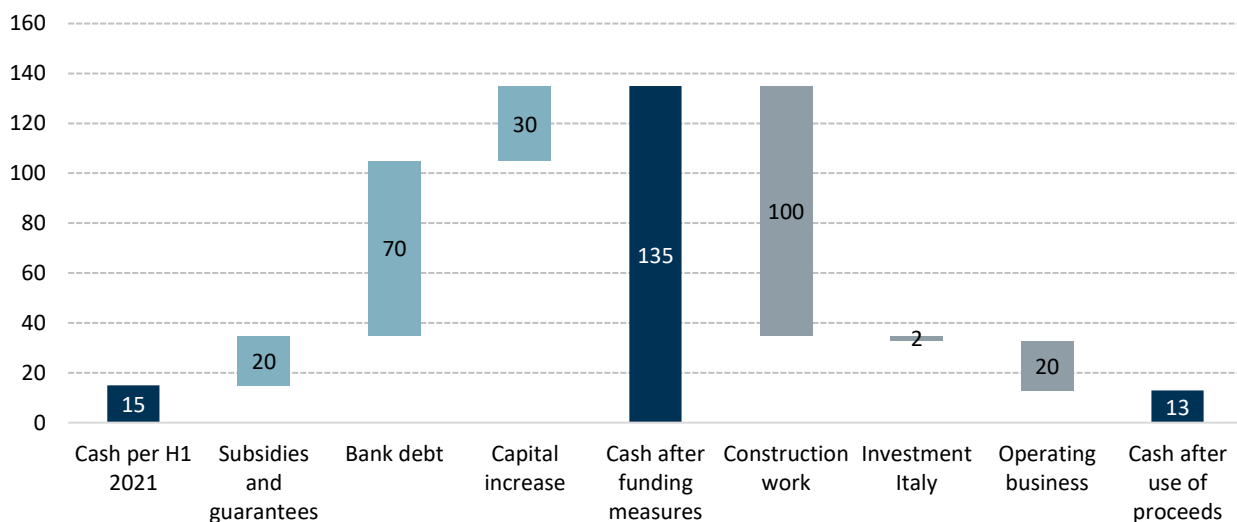

Source: Enapter, Pareto Securities Research

The investment volume is expected to be around EUR 100m and should be financed from a mix of own funds as well as debt and government subsidies. Enapter has already received a non-refundable grant in the amount of EUR 7.2m from the German promotional bank KfW. Taking into account Germany’s announcement with regard to the national hydrogen strategy and the political willingness to set up a competitive hydrogen industry, we believe Enapter should not struggle to achieve further subsidies and government guarantees. We believe that further subsidies and traditional mortgage financing can make up 70% of the investment volume. Together with financing requirements of the operating business and further investments in Italy (around EUR 2m), Enapter puts the total volume of funds required at EUR 120m. The contribution of the expected capital increase is amounted to EUR 30m. Enapter has still an authorized capital in the amount of EUR 9.17m.

In addition to the above-mentioned EUR 7.2m KfW grant, Enapter has further received EUR 9.4m from North-Rhine Westphalia and EUR 5.6m from the German Ministry of Research. However, both grants are in connection with the further development of Enapter’s electrolyzers and related to the planned construction. In total, Enapter has received EUR 22.2m of grants from Germany government authorities so far in 2021.

Exhibit 30: Capex and free cash flow development

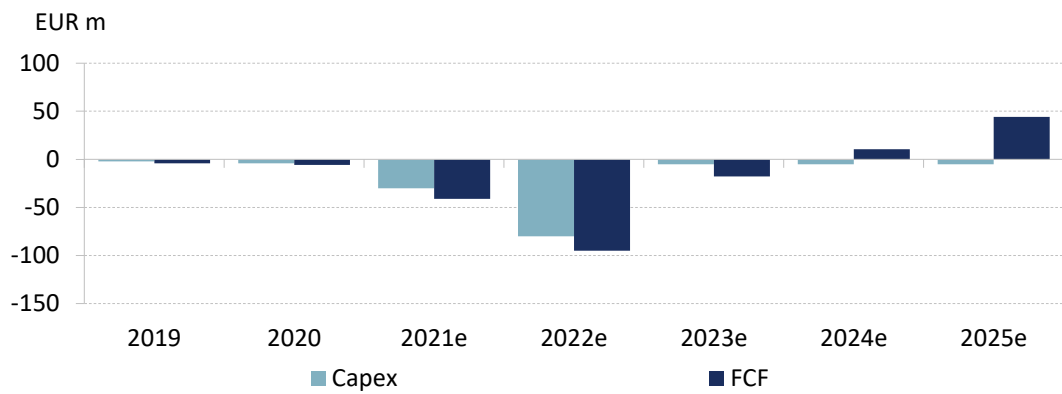

Source: Enapter, Pareto Securities Research

The expected capital increase and the debt financing will be sufficient enough to finance the construction of the new production facility. However, we believe, Enapter will require a further capital increase in FY 2022e to cover cash burn (PAsE EUR 3-4m per quarter) in FY 2022e and partially FY 2023e.

Valuation

Our valuation of Enapter is based on a DCF model as well as a peer group model. We acknowledge, that the DCF model is appropriate to reflect the long-term prospects of the company as well as of the hydrogen market. However, it should be kept in mind, that it will likely take some years before Enapter will achieve sizeable revenues and related earnings.

In addition to the DCF model, we use a peer group valuation. There is a significant number of listed companies with a very similar business model as Enapter and a strong focus on the hydrogen market. These provide in our view a good basis for a relative valuation.

DCF valuation

We have used a 3 stage DCF model. In phase I, we have made detailed forecasts of future earnings and cash flows until FY 2025e, as outlined in our financials sections. In phase II, we are continuously reducing our growth expectations as well as our margin assumption. In phase III we keep the EBIT margin stable at 15% and consider a terminal growth rate of 3%.

In order to reflect the young history with poor earnings, we incorporate a WACC of 10.0% (beta of 1.8).

Based on our DCF model, we derive a fair value of EUR 29.1 per share.

Exhibit 31: DCF model

EUR m	Phase I					Phase II					Phase III		
	2021e	2022e	2023e	2024e	2025e	2026e	2027e	2028e	2029e	2030e			
Revenues	9	42	130	227	294	389	499	635	804	1,004			
growth rate	322.6%	382.7%	207.6%	74.4%	29.7%	28.9%	28.1%	27.3%	26.6%	25.0%			
EBIT	-11	-12	3	29	48	62	79	99	123	151			
EBIT margin	-123.8%	-27.9%	19%	12.6%	16.3%	16.0%	15.8%	15.5%	15.3%	15.0%			
Tax	0.0	0.0	0.0	0.0	0.0	-16.9	-21.6	-27.1	-33.7	-41.4			
Tax rate	0%	0%	0%	0%	0%	28%	28%	28%	28%	28%			
Depr. & Amort.	1.5	4.5	4.4	4.7	4.6	9.7	14.7	20.2	26.5	34.3			
% of sales	16.9%	10.6%	3.4%	2.1%	1.6%	2.5%	3.0%	3.2%	3.3%	3.4%			
Capex	-30.0	-80.0	-5.0	-5.0	-5.0	-10.1	-15.2	-20.8	-27.2	-35.2			
% of sales	342.9%	189.4%	3.8%	2.2%	1.7%	2.6%	3.1%	3.3%	3.4%	3.5%			
Change in WC & P	-1.7	-6.3	-17.5	-8.0	-1.3	-1.7	-2.3	-3.0	-3.8	-5.0			
% of sales	18.9%	14.8%	13.5%	3.5%	0.4%	0.4%	0.5%	0.5%	0.5%	0.5%			
Free Cash Flow	-41.0	-93.6	-15.6	20.2	46.3	43.4	54.3	67.9	84.4	103.4	1,513		
growth rate	nm	nm	-83.3%	nm	nm	-6%	25.2%	25.0%	24.2%	22.5%	3.0%		
Present Value FCF	-39.6	-82.1	-12.4	14.6	30.5	26.0	29.5	33.6	37.9	42.2	617.2		
PV Phase I		-89				Risk free rate	2.00%		Targ. equity ratio	90%			
PV Phase II		169				Premium Equity	5.00%		Beta	1.8			
PV Phase III		617				Premium Debt	3.00%		WACC	10.0%			
Enterprise value		697				Sensitivity			Growth in phase III				
- Net Debt (Cash)		-11							2.0%	2.5%	3.0%	3.5%	4.0%
- Pension Provisions		0				9.0%	31.6	33.8	36.4	39.5	43.2		
- Minorities & Peripherals		0				9.5%	28.4	30.3	32.5	35.0	37.9		
+ MV of financial assets						10.0%	25.7	27.3	29.1	31.1	33.5		
- Paid-out dividends for last FY						10.5%	23.3	24.6	26.1	27.9	29.9		
+/- Other EV items						11.0%	21.2	22.3	23.6	25.1	26.7		
Equity value		708											
Number of shares		24.4											
Value per share (€)		29.1											
Current Price (€)		26.8											
Upside		9%											

Source: Pareto Securities Research

Peer group model

Our peer consists of companies that have their focus on the hydrogen market. The companies are very comparable in terms of business model, product focus as well as end markets. Consequently, the peers also show a similar picture in terms of revenue size and earnings. Given the fact, that P/E, EV/EBIT and EV/EBITDA multiples are consistently negative or exorbitantly high, we focus in our peer group comparison on the EV/sales multiples. This is not unusual for companies on a strong growth trajectory which still need scale to turn profitable. For our EV/sales multiple approach, we use the fiscal years 2022 and 2023 as a basis, as we see a greater comparability in terms of revenue growth by then.

Exhibit 32: Peer group model

Company	CUR	MarketCap	EV/EBIT 2021e	EV/EBIT 2022e	EV/EBIT 2023e	EV/EBITDA 2021e	EV/EBITDA 2022e	EV/EBITDA 2023e	EV/Sales 2021e	EV/Sales 2022e	EV/Sales 2023e
AFC Energy plc	£	432	-71.5	nm	nm	-73.0	nm	nm	218.6	nm	nm
Aker Clean Hydrogen AS	NOK	4,831	-90.6	-45.4	-32.2	-90.6	-45.4	-32.2	nm	nm	nm
Ballard Power Systems Inc.	\$	4,464	-46.7	-53.1	-86.7	-50.4	-64.3	-114.8	31.7	23.6	15.9
FuelCell Energy, Inc.	\$	1,958	-31.7	-43.0	-52.5	-53.8	-155.5	372.3	26.7	17.2	9.3
Green Hydrogen Systems A/S	DKK	3,448	-20.0	-17.3	-16.8	-23.0	-23.4	-27.1	47.0	28.7	10.4
ITM Power PLC	£	2,141	-109.5	-213.5	876.0	-144.2	-1332.0	224.6	74.3	26.6	16.6
McPhy Energy SA	€	425	-18.6	-17.5	-23.1	-21.5	-22.4	-35.0	17.6	12.5	6.6
NEL ASA	NOK	20,431	-39.9	-48.5	-115.2	-55.4	-90.2	645.6	20.0	13.6	8.2
Plug Power Inc.	\$	14,416	-60.8	-166.8	1230.9	-115.5	354.7	78.0	23.0	16.3	11.1
Median			-46.7	-46.9	-27.7	-55.4	-54.8	25.5	29.2	17.2	10.4
Enapter AG		650			298.4			108.3	73.1	17.4	5.8
relative					-1078.6%			425.3%	250.3%	100.8%	55.5%
Fair value per share at peer median									10.9	26.4	51.5
Fair value / share (av.)		39.0									

Source: FactSet, Pareto Securities Research

Based on our peer group model, we derive a fair value of EUR 39.0 per share.

Exhibit 33: Share price performance of peer companies

Company	Share price	in % of		Share price performance (in %)					
		52Wk high	52Wk low	1 Mo	3 Mo	6 Mo	12 Mo	qtd	ytd
AFC Energy plc	0.59	-39.0	248.7	5.3	9.9	-11.1	174.3	-9.3	-27.5
Aker Clean Hydrogen AS	7.03	-55.6	5.7	-4.7	-7.6	-	-	-12.8	-
Ballard Power Systems Inc.	15.00	-64.5	18.3	-1.0	5.0	-53.3	-3.5	-17.2	-35.9
FuelCell Energy, Inc.	6.07	-79.4	284.2	-7.3	-23.6	-72.6	113.7	-31.8	-45.7
Green Hydrogen Systems A/S	42.05	-14.1	3.7	-2.4	-	-	-	-2.4	-
ITM Power PLC	3.89	-46.8	74.8	-0.2	20.3	-33.9	43.3	-15.4	-25.3
McPhy Energy SA	15.27	-64.0	0.7	-14.9	-42.5	-52.7	-25.9	-29.7	-56.3
NEL ASA	14.02	-61.4	-3.1	-21.9	-20.4	-55.3	-27.9	-32.4	-53.1
Plug Power Inc.	25.10	-66.8	137.7	-3.5	0.6	-55.4	105.7	-26.6	-26.0
Enapter	26.70	-48%	893%	-2.2	17.4	-20.6	661.4	-0.9	-0.1

Source: FactSet, Pareto Securities Research

From the equally weighted average of both methods, we derive a target price of EUR 34.00 per share, which implies an upside potential of 27%.

Appendix

Management

CEO Sebastian-Justus Schmidt



- More than 30 years of experience in software development.
- Founder of mobile software company SPB Software, which he sold to Russian internet company Yandex in 2011.
- As a result of personal positive experiences with the use of hydrogen, Mr. Schmidt decided to acquire an Italian electrolyser manufacturer, which was the foundation for today's Enapter.
- Enapter was started in 2017.

CFO Gerrit Kaufhold



- Mr. Kaufhold was appointed as CFO in May 2021.
- At Enapter, he is responsible for finance, legal and investor relations as well as compliance.
- Prior to that, he was managing partner of a medium-sized auditing company for many years, where he was an advisor for the reverse merger of Enapter.
- Mr. Kaufhold started his career as a tax consultant and auditor, among others for a Big4 consulting.

Shareholder structure

Exhibit 34: CEO holds clear majority in the company

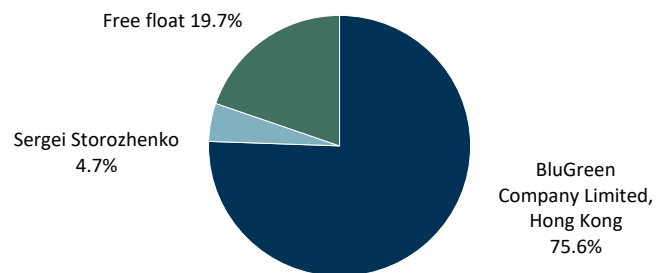

Source: Enapter, Pareto Securities Research

BluGreen is the holding company of the CEO Sebastian-Justus Schmidt, who holds 96,7% of the shares in BluGreen.

Overview of competitors

Exhibit 35: Overview of electrolyser manufacturers

Alkaline Electrolysers		PEM Electrolysers	
Company	Manufacturing site	Company	Manufacturing site
Aquahydx	Australia, USA	Arevah 2	France and Germany
Asahi Kasei	Japan	Carbotech	Germany
Cockergrill Jingli	China	Cummings - Hydrogenics	Belgium, Canada and Germany
Cummings - Hydrogenics	Belgium, Canada and Germany	Denora	Italy, Japan and USA
Denora	Italy, Japan and USA	Giner ELX	USA
Green Hydrogen Systems	Denmark	Hitachi Zosen	Japan
Hitachi Zosen	Japan	Honda	Japan
HydrogenPro	Norway	iGas	Germany
Kobelco	Japan	ITM	UK
Kumatec	Germany	Kobelco	Japan
McPhy	France, Italy and Germany	NEL Hydrogen	Denmark, Norway and USA
NEL Hydrogen	Denmark, Norway and USA	Plug Power	USA
Peric	China	Siemens Energy	Germany
Shanghai Zhizen	China	Teledyne	USA
Tianjin	China		
ThyssenKrupp Uhde	Germany		

SOCE Electrolysers		AEM Electrolysers	
Company	Manufacturing site	Company	Manufacturing site
Haldor Topse	Denmark	Enapter	Italy and Germany
Solid Power	Italy, Switzerland, Germany and Austria		
Sunfire	Germany		
Toshiba	Japan		

Source: IRENA, Pareto Securities Research

Exhibit 36: Different types of hydrogen

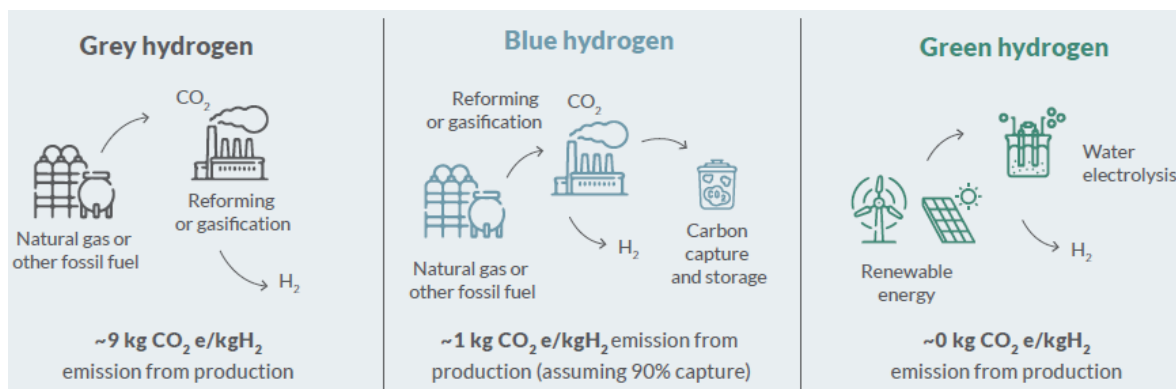

Source: Green Hydrogen Systems, Pareto Securities Research

Notes

PROFIT & LOSS (fiscal year) (EURm)	2016	2017	2018	2019	2020	2021e	2022e	2023e
Revenues	-	-	-	1	2	9	42	130
EBITDA	-	-	-	(1)	(3)	(9)	(7)	7
Depreciation & amortisation	-	-	-	(0)	(1)	(1)	(4)	(4)
EBIT	-	-	-	(2)	(4)	(11)	(12)	3
Net interest	-	-	-	(0)	(0)	(0)	(1)	(2)
Other financial items	-	-	-	-	-	-	-	-
Profit before taxes	-	-	-	(2)	(4)	(11)	(13)	0
Taxes	-	-	-	(0)	(0)	-	-	-
Minority interest	-	-	-	0	0	-	-	-
Net profit	-	-	-	(2)	(4)	(11)	(13)	0
EPS reported	-	-	-	(0.48)	(1.23)	(0.47)	(0.54)	0.01
EPS adjusted	-	-	-	-	-	-	-	-
DPS	-	-	-	-	-	-	-	-
BALANCE SHEET (EURm)	2016	2017	2018	2019	2020	2021e	2022e	2023e
Tangible non current assets	-	-	1	1	3	29	102	100
Other non-current assets	-	-	0	2	4	6	9	11
Other current assets	-	-	1	3	3	8	30	87
Cash & equivalents	-	-	1	1	4	57	7	19
Total assets	-	-	3	8	15	100	147	218
Total equity	-	-	0	4	9	46	33	33
Interest-bearing non-current debt	-	-	-	-	-	45	90	120
Interest-bearing current debt	-	-	-	-	-	-	-	-
Other Debt	-	-	3	4	6	9	24	64
Total liabilities & equity	-	-	3	8	15	100	147	218
CASH FLOW (EURm)	2016	2017	2018	2019	2020	2021e	2022e	2023e
Cash earnings	-	-	(0)	(1)	(2)	(13)	(21)	(30)
Change in working capital	-	-	0	(0)	0	2	6	18
Cash flow from investments	-	-	-	(3)	(4)	(30)	(80)	(5)
Cash flow from financing	-	-	-	5	9	93	45	30
Net cash flow	-	-	-	1	3	52	(50)	12
CAPITALIZATION & VALUATION (EURm)	2016	2017	2018	2019	2020	2021e	2022e	2023e
Share price (EUR end)	3.16	9.8	6.4	1.17	26.7	26.8	26.8	26.8
Number of shares end period	-	-	-	3	3	24	24	24
Net interest bearing debt	-	-	(1)	(1)	(4)	(12)	83	101
Enterprise value	-	-	(1)	2	74	640	735	753
EV/Sales	-	-	-	2.5	35.6	-	17.4	5.8
EV/EBITDA	-	-	-	-	-	-	-	-
EV/EBIT	-	-	-	-	-	-	-	-
P/E reported	-	-	-	-	-	-	-	-
P/E adjusted	-	-	-	-	-	-	-	-
P/B	-	-	-	0.9	8.9	14.1	19.6	19.5
FINANCIAL ANALYSIS & CREDIT METRICS	2016	2017	2018	2019	2020	2021e	2022e	2023e
ROE adjusted (%)	-	-	-	-	-	-	-	-
Dividend yield (%)	-	-	-	-	-	-	-	-
EBITDA margin (%)	-	-	-	-	-	-	-	5.3
EBIT margin (%)	-	-	-	-	-	-	-	1.9
NIBD/EBITDA	-	-	-	1.08	1.46	1.24	(11.40)	14.56
EBITDA/Net interest	-	-	-	-	-	-	-	-

Disclaimer and legal disclosures

Origin of the publication or report

This publication or report originates from Pareto Securities AS, reg. no. 956 632 374 (Norway), Pareto Securities AS, Frankfurt branch, reg. no. DE 320 965 513 / HRB 109177 (Germany) or Pareto Securities AB, reg. no. 556206-8956 (Sweden) (together the Group Companies or the "Pareto Securities Group") acting through their common unit Pareto Securities Research. The Group Companies are supervised by the Financial Supervisory Authority of their respective home countries.

Content of the publication or report

This publication or report has been prepared solely by Pareto Securities Research.

Opinions or suggestions from Pareto Securities Research may deviate from recommendations or opinions presented by other departments or companies in the Pareto Securities Group. The reason may typically be the result of differing time horizons, methodologies, contexts or other factors.

Sponsored research

Please note that if this report is labelled as "sponsored research" on the front page, Pareto Securities has entered into an agreement with the company about the preparation of research reports and receives compensation from the company for this service. Sponsored research is prepared by the Research Department of Pareto Securities without any instruction rights by the company. Sponsored research is however commissioned for and paid by the company and such material is considered by Pareto Securities to qualify as an acceptable minor non-monetary benefit according to the EU MiFID II Directive.

Basis and methods for assessment

Opinions and price targets are based on one or more methods of valuation, for instance cash flow analysis, use of multiples, behavioral technical analyses of underlying market movements in combination with considerations of the market situation and the time horizon. Key assumptions of forecasts, price targets and projections in research cited or reproduced appear in the research material from the named sources. The date of publication appears from the research material cited or reproduced. Opinions and estimates may be updated in subsequent versions of the publication or report, provided that the relevant company/issuer is treated anew in such later versions of the publication or report.

Pareto Securities Research may provide credit research with more specific price targets based on different valuation methods, including the analysis of key credit ratios and other factors describing the securities creditworthiness, peer group analysis of securities with similar creditworthiness and different DCF-valuations. All descriptions of loan agreement structures and loan agreement features are obtained from sources which Pareto Securities Research believes to be reliable, but Pareto Securities Research does not represent or warrant their accuracy. Be aware that investors should go through the specific complete loan agreement before investing in any bonds and not base an investment decision based solely on information contained in this publication or report.

Pareto Securities Research has no fixed schedule for updating publications or reports.

Unless otherwise stated on the first page, the publication or report has not been reviewed by the issuer before dissemination. In instances where all or part of a report is presented to the issuer prior to publication, the purpose is to ensure that facts are correct.

Validity of the publication or report

All opinions and estimates in this publication or report are, regardless of source, given in good faith and may only be valid as of the stated date of this publication or report and are subject to change without notice.

No individual investment or tax advice

The publication or report is intended only to provide general and preliminary information to investors and shall not be construed as the basis for any investment decision. This publication or report has been prepared by Pareto Securities Research as general information for private use of investors to whom the publication or report has been distributed, but it is not intended as a personal recommendation of particular financial instruments or strategies and thus it does not provide individually tailored investment advice, and does not take into account the individual investor's particular financial situation, existing holdings or liabilities, investment knowledge and experience, investment objective and horizon or risk profile and preferences. The investor must particularly ensure the suitability of an investment as regards his/her financial and fiscal situation and investment objectives. The investor bears the risk of losses in connection with an investment.

Before acting on any information in this publication or report, we recommend consulting your financial advisor.

The information contained in this publication or report does not constitute advice on the tax consequences of making any particular investment decision. Each investor shall make his/her own appraisal of the tax and other financial merits of his/her investment.

Sources

This publication or report may be based on or contain information, such as opinions, recommendations, estimates, price targets and valuations which emanate from Pareto Securities Research' analysts or representatives, publicly available information, information from other units or companies in the Group Companies, or other named sources.

To the extent this publication or report is based on or contains information emanating from other sources ("Other Sources") than Pareto Securities Research ("External Information"), Pareto Securities Research has deemed the Other Sources to be reliable but neither the companies in the Pareto Securities Group, others associated or affiliated with said companies nor any other person, guarantee the accuracy, adequacy or completeness of the External Information.

Ratings

Equity ratings:	"Buy"	Pareto Securities Research expects this financial instrument's total return to exceed 10% over the next 12 months
	"Hold"	Pareto Securities Research expects this financial instrument's total return to be between -10% and 10% over the next 12 months
	"Sell"	Pareto Securities Research expects this financial instrument's total return to be negative by more than 10% over the next 12 months

Analysts Certification

The research analyst(s) whose name(s) appear on research reports prepared by Pareto Securities Research certify that: (i) all of the views expressed in the research report accurately reflect their personal views about the subject security or issuer, and (ii) no part of the research analysts' compensation was, is, or will be directly or indirectly related to the specific recommendations or views expressed by the research analysts in research reports that are prepared by Pareto Securities Research.

The research analysts whose names appear on research reports prepared by Pareto Securities Research received compensation that is based upon various factors including Pareto Securities' total revenues, a portion of which are generated by Pareto Securities' investment banking activities.

Limitation of liability

Pareto Securities Group or other associated and affiliated companies assume no liability as regards to any investment, divestment or retention decision taken by the investor on the basis of this publication or report. In no event will entities of the Pareto Securities Group or other associated and affiliated companies be liable for direct, indirect or incidental, special or consequential damages resulting from the information in this publication or report.

Neither the information nor any opinion which may be expressed herein constitutes a solicitation by Pareto Securities Research of purchase or sale of any securities nor does it constitute a solicitation to any person in any jurisdiction where solicitation would be unlawful. All information contained in this research report has been compiled from sources believed to be reliable. However, no representation or warranty, express or implied, is made with respect to the completeness or accuracy of its contents, and it is not to be relied upon as authoritative.

Risk information

The risk of investing in certain financial instruments, including those mentioned in this document, is generally high, as their market value is exposed to a lot of different factors such as the operational and financial conditions of the relevant company, growth prospects, change in interest rates, the economic and political environment, foreign exchange rates, shifts in market sentiments etc. Where an investment or security is denominated in a different currency to the investor's currency of reference, changes in rates of exchange may have an adverse effect on the value, price or income of or from that investment to the investor. Past performance is not a guide to future performance. Estimates of future performance are based on assumptions that may not be realized. When investing in individual shares, the investor may lose all or part of the investments.

Conflicts of interest

Companies in the Pareto Securities Group, affiliates or staff of companies in the Pareto Securities Group, may perform services for, solicit business from, make a market in, hold long or short positions in, or otherwise be interested in the investments (including derivatives) of any company mentioned in the publication or report. In addition Pareto Securities Group, or affiliates, may from time to time have a broking, advisory or other relationship with a company which is the subject of or referred to in the relevant Research, including acting as that company's official or sponsoring broker and providing investment banking or other financial services. It is the policy of Pareto to seek to act as corporate adviser or broker to some of the companies which are covered by Pareto Securities Research. Accordingly companies covered in any Research may be the subject of marketing initiatives by the Investment Banking Department.

To limit possible conflicts of interest and counter the abuse of inside knowledge, the analysts of Pareto Securities Research are subject to internal rules on sound ethical conduct, the management of inside information, handling of unpublished research material, contact with other units of the Group Companies and personal account dealing. The internal rules have been prepared in accordance with applicable legislation and relevant industry standards. The object of the internal rules is for example to ensure that no analyst will abuse or cause others to abuse confidential information. It is the policy of Pareto Securities Research that no link exists between revenues from capital markets activities and individual analyst remuneration. The Group Companies are members of national stockbrokers' associations in each of the countries in which the Group Companies have their head offices. Internal rules have been developed in accordance with recommendations issued by the stockbrokers associations. This material has been prepared following the Pareto Securities Conflict of Interest Policy.

The guidelines in the policy include rules and measures aimed at achieving a sufficient degree of independence between various departments, business areas and sub-business areas within the Pareto Securities Group in order to, as far as possible, avoid conflicts of interest from arising between such departments, business areas and sub-business areas as well as their customers. One purpose of such measures is to restrict the flow of information between certain business areas and sub-business areas within the Pareto Securities Group, where conflicts of interest may arise and to safeguard the impartialness of the employees. For example, the Investment Banking departments and certain other departments included in the Pareto Securities Group are surrounded by arrangements, so-called Chinese Walls, to restrict the flows of sensitive information from such departments. The internal guidelines also include, without limitation, rules aimed at securing the impartialness of, e.g., analysts working in the Pareto Securities Research departments, restrictions with regard to the remuneration paid to such analysts, requirements with respect to the independence of analysts from other departments within the Pareto Securities Group rules concerning contacts with covered companies and rules concerning personal account trading carried out by analysts.

Distribution restriction

The securities referred to in this publication or report may not be eligible for sale in some jurisdictions and persons into whose possession this document comes should inform themselves about and observe any such restrictions. This publication or report is not intended for and must not be distributed to private customers in the US, or retail clients in the United Kingdom, as defined by the Financial Conduct Authority (FCA).

This research is only intended for and may only be distributed to institutional investors in the United States and U.S. entities seeking more information about any of the issuers or securities discussed in this report should contact Pareto Securities Inc. at 150 East 52nd Street, New York, NY 10022, Tel. 212 829 4200.

Pareto Securities Inc. is a broker-dealer registered with the U.S. Securities and Exchange Commission and is a member of FINRA & SPC. U.S. To the extent required by applicable U.S. laws and regulations, Pareto Securities Inc. accepts responsibility for the contents of this publication. Investment products provided by or through Pareto Securities Inc. or Pareto Securities Research are not FDIC insured, may lose value and are not guaranteed by Pareto Securities Inc. or Pareto Securities Research. Investing in non-U.S. securities may entail certain risks. This document does not constitute or form part of any offer for sale or subscription, nor shall it or any part of it form the basis of or be relied on in connection with any contract or commitment whatsoever. The securities of non-U.S. issuers may not be registered with or subject to SEC reporting and other requirements. The information available about non-U.S. companies may be limited, and non-U.S. companies are generally not subject to the same uniform auditing and reporting standards as U.S. companies. Market rules, conventions and practices may differ from U.S. markets, adding to transaction costs or causing delays in the purchase or sale of securities. Securities of some non-U.S. companies may not be as liquid as securities of comparable U.S. companies. Fluctuations in the values of national currencies, as well as the potential for governmental restrictions on currency movements, can significantly erode principal and investment returns.

Pareto Securities Research may have material conflicts of interest related to the production or distribution of this research report which, with regard to Pareto Securities Research, are disclosed herein.

Distribution in Singapore

Pareto Securities Pte Ltd holds a Capital Markets Services License is an exempt financial advisor under Financial Advisers Act, Chapter 110 ("FAA") of Singapore and a subsidiary of Pareto Securities AS.

This report is directed solely to persons who qualify as "accredited investors", "expert investors" and "institutional investors" as defined in section 4A(1) Securities and Futures Act, Chapter 289 ("SFA") of Singapore. This report is intended for general circulation amongst such investors and does not take into account the specific investment objectives, financial situation or particular needs of any particular person. You should seek advice from a financial adviser regarding the suitability of any product referred to in this report, taking into account your specific financial objectives, financial situation or particular needs before making a commitment to purchase any such product. Please contact Pareto Securities Pte Ltd, 16 Collyer Quay, # 2 7-02 Income at Raffles, Singapore 049318, at +65 6408 9800 in matters arising from, or in connection with this report.

Additional provisions on Recommendations distributed in the Canada

Canadian recipients of this research report are advised that this research report is not, and under no circumstances is it to be construed as an offer to sell or a solicitation of or an offer to buy any securities that may be described herein. This research report is not, and under no circumstances is it to be construed as, a prospectus, offering memorandum, advertisement or a public offering in Canada of such securities. No securities commission or similar regulatory authority in Canada has reviewed or in any way passed upon this research report or the merits of any securities described or discussed herein and any representation to the contrary is an offence. Any securities described or discussed within this research report may only be distributed in Canada in accordance with applicable provincial and territorial securities laws. Any offer or sale in Canada of the securities described or discussed herein will be made only under an exemption from the requirements to file a prospectus with the relevant Canadian securities regulators and only by a dealer properly registered under applicable securities laws or, alternatively, pursuant to an exemption from the dealer registration requirement in the relevant province or territory of Canada in which such offer or sale is made. Under no circumstances is the information contained herein to be construed as investment advice in any province or territory of Canada nor should it be construed as being tailored to the needs of the recipient. Canadian recipients are advised that Pareto Securities AS, its affiliates and its authorized agents are not responsible for, nor do they accept, any liability whatsoever for any direct or consequential loss arising from any use of this research report or the information contained herein.

Distribution in United Kingdom

This publication is issued for the benefit of persons who qualify as eligible counterparties or professional clients and should be made available only to such persons and is exempt from the restriction on financial promotion in s21 of the Financial Services and Markets Act 2000 in reliance on provision in the FPO.

Copyright

This publication or report may not be mechanically duplicated, photocopied or otherwise reproduced, in full or in part, under applicable copyright laws. Any infringement of Pareto Securities Research's copyright can be pursued legally whereby the infringer will be held liable for any and all losses and expenses incurred by the infringement.

Appendix A

Disclosure requirements in accordance with Commission Delegated Regulation (EU) 2016/958 and the FINRA Rule 2241

The below list shows companies where Pareto Securities AS - together with affiliated companies and/or persons - owns a net long position of the shares exceeding 0,5 % of the total issued share capital in any company where a recommendation has been produced or distributed by Pareto Securities AS.

Companies	No. of shares	Holdings in %	Companies	No. of shares	Holdings in %
Bonheur	240,945	0.57%	Sparebank 1SR-Bank	1,850,014	0.72%
Pareto Bank	15,236,002	21.94%	SpareBank 1Østfold Akershus	12,15,116	9.81%
Selvaag Bolig	3,126,925	3.33%	SpareBank 1Østlandet	3,832,163	3.61%
SpareBank 1BV	1,771,308	2.81%	Sparebanken Møre	305,239	3.09%
Sparebank 1Nord-Norge	4,279,097	4.26%	Sparebanken Sør	433,744	2.77%
SpareBank 1Ringerike Hadel	100,000	0.64%	Sparebanken Vest	6,861,616	6.39%
Sparebank 1SMN	1,920,442	1.48%			

Pareto Securities AS may hold financial instruments in companies where a recommendation has been produced or distributed by Pareto Securities AS in connection with rendering investment services, including Market Making.

Please find below an overview of material interests in shares held by employees in Pareto Securities AS, in companies where a recommendation has been produced or distributed by Pareto Securities AS. "By material interest" means holdings exceeding a value of NOK 50 000.

Company	Analyst holdings*	Total holdings	Company	Analyst holdings*	Total holdings	Company	Analyst holdings*	Total holdings
AF Gruppen	0	1,825	Flex LNG	0	3,532	Panoro Energy	0	30,344
Aker ASA	500	2,405	Frontline	0	78,708	Pareto Bank	0	1,265,656
Aker BP	0	23,651	Gjensidige Forsikring	0	7,728	Pexip Holding	0	63,283
Aker Carbon Capture	0	120,621	Golden Ocean Group	0	1,433	Protector Forsikring	0	14,000
Aker Offshore Wind	0	165,278	Grieg Seafood	0	8,127	Quantafuel	0	10,797
Aker Solutions	0	3,728	Hafnia Ltd.	0	10,000	REC Silicon	0	36,816
American Shipping Co.	0	13,300	Huddly	0	980,874	SalMar	0	2,709
Aprila Bank ASA	0	22,675	Hunter Group ASA	0	308,500	Salmon Evolution	0	100,000
Archer	0	30,170	HydrogenPro	0	37,552	Sandnes Sparebank	0	4,013
ArcticZymes Technologies	0	684	Ice Fish Farm	0	2,000	Scatec	0	20,302
Atlantic Sapphire	0	13,610	ice Group ASA	0	200,000	Selvaag Bolig	0	2,050
Austevoll Seafood	0	4,235	Icelandic Salmon AS	0	535	Sparebank 1Nord-Norge	0	3,350
Avance Gas	0	3,362	Kalera	0	54,027	Sparebank 1SMN	0	12,740
B2Holding AS	0	20,075	Kitron	0	18,386	Sparebank 1SR-Bank	0	8,505
BASF	270	270	Komplett Bank	0	10,140	SpareBank 1Østfold Akershus	0	1,252
Belships	0	12,595	Kongsberg Gruppen	0	36,023	SpareBank 1Østlandet	0	8,621
Bonheur	0	32,075	KWS	75	75	Sparebanken Sør	0	16,435
Borregaard ASA	0	650	Lerøy Seafood Group	0	40,478	Sparebanken Vest	0	16,735
Bouvet	0	2,940	Mercell	0	22,998	Sparebanken Øst	0	1,500
BRABank	0	31,499	Mowi	0	3,761	Stolt-Nielsen	0	1,817
BW Energy	0	55,050	MPC Container Ships	0	39,037	Storebrand	0	25,698
BW Offshore	0	16,076	Nordic Semiconductor	0	4,681	Subsea 7	0	11,726
Cloudberry Clean Energy	0	52,031	Noreco	0	790	Telenor	0	9,752
DNB	0	43,094	Norsk Hydro	0	92,019	Vow	0	8,681
DNO	0	151,978	Norske Skog	0	98,225	Wallenius Wilhelmsen	0	57,570
Elkem	0	35,426	NTS	0	2,272	XXL	0	16,923
Entra	0	9,977	Ocean Yield	0	90,410	Yara	0	14,133
Equinor	0	2,900	OHT	0	6,650	Zaptec	0	4,000
Europris	0	11,208	Okeanis Eco Tankers	0	2,000			
Fjordkraft Holding	0	12,855	Orkla	0	20,540			

This overview is updated monthly (last updated 15.08.2021).

*Analyst holdings refer to positions held by the Pareto Securities AS analyst covering the company.

Appendix B

Disclosure requirements in accordance with Article 6(1)(c)(iii) of Commission Delegated Regulation (EU) 2016/958

Overview over issuers of financial instruments where Pareto Securities AS have prepared or distributed investment recommendation, where Pareto Securities AS have been lead manager/co-lead manager or have rendered publicly known not immaterial investment banking services over the previous 12 months:

24SevenOffice Scandinavia	DigiPlex	Kistosplc.	Panoro Energy	WatercirclesForsikring
2GEnergy	DLT	KlavenessCombination CarriersASA	Pelagia Holding AS	West Coast Salmon
Avanzia Bank S.A.	Documaster AS	KLP	PetroNor E&P	Wheel.me
Africa Energy Corp Corp	EcoOnline	Komplett ASA	PetroTal	Xeneta AS
Aker ASA	ELOP	Komplett Bank	PHM Group	ZTL Payment Solution AS
Aker Clean Hydrogen	Endur ASA	Kraft Bank	Ping Petroleum UK Limited	Ørn Software
Aker Horizons	Energiean Israel Finance Ltd.	Lakers Holding AS	Pronofa AS	
Akershus Energi	Enviv AS (Bookis)	Lumarine AS	Proximar Seafood	
Akva Group	Fertiberia S.A.R.L.	Maha Energy	Pryme	
Alussa Energy Acquisition Corp (Freyr)	Flexistore AS	Malorama Holding AS	Quantafuel	
Arcane Crypto	Funkwerk AG	Mathesa Bostadsbolaget AB	REC Silicon	
Arctic Fish	Genel Energy	Meltwater	Saga Robotics	
ArendalsFossekompani	Gjensidige Forsikring	Mercell	Salmon Evolution	
Attensi	Golden Ocean Group	Mintra Group	Scorpio Bulkers	
Belships	Goliath Offshore	Modex AS	Seafire AB	
BioInvent	Halodi Robotics AS	MPC Container Ships	SFL Corporation Ltd	
Biomega Group AS	Heimdall Power	Mutares SE & Co. KGaA	SGL TransGroup International A/S	
Bonheur	HKN Energy Ltd	Müller Medien GmbH (United Vertical)	Shamaran Petroleum	
Brooge Energy Limited	Hofseth BioCare	Navigator Holdings Ltd.	Siccar Point Energy	
Bulk Infrastructure Holding	House of Control	Navios	Skitude	
BWEnergy	Huddly	Next Biometrics Group	Smart Wires Inc.	
BWLPG	HydrogenPro	Nordic Halibut	Strandline Resources Limited	
Cavai AS	Ice Group Scandinavia Holdings AS	Noreco	Talos Energy Inc	
CentralNic Group PLC	Idavang A/S	Norlandia Health & Care Group AS	Tise AS	
Circa Group	Instabank ASA	Norse Atlantic	Trønderenergi AS	
Cloudberry Clean Energy	Kalera	Norske Skog	Vegfinans AS	
CrayoNano AS	Kentech Global Plc	Norwegian Block Exchange	Viking ACQ 1 AS, SPAC	
Dampskibsselskabet NORDEN A/S	Keppel FELS Limited	OHT	Vow	

This overview is updated monthly (this overview is for the period 31.07.2020 – 31.07.2021).

Appendix C

Disclosure requirements in accordance with Article 6(3) of Commission Delegated Regulation (EU) 2016/958

Distribution of recommendations

Recommendation	% distribution
Buy	67%
Hold	31%
Sell	2%

Distribution of recommendations (transactions*)

Recommendation	% distribution
Buy	93%
Hold	7%
Sell	0%

* Companies under coverage with which Pareto Securities Group has on-going or completed public investment banking services in the previous 12 months.

This overview is updated monthly (last updated 16.08.2021).

Appendix D

This section applies to research reports prepared by Pareto Securities AB.

Disclosure of positions in financial instruments

The beneficial holding of the Pareto Group is 1 % or more of the total share capital of the following companies included in Pareto Securities AB's research coverage universe: None

The Pareto Group has material holdings of other financial instruments than shares issued by the following companies included in Pareto Securities AB's research coverage universe: None

Disclosure of assignments and mandates

Overview over issuers of financial instruments where Pareto Securities AB has prepared or distributed investment recommendation, where Pareto Securities AB has been lead manager or co-lead manager or has rendered publicly known not immaterial investment banking services over the previous twelve months:

24SevenOffice Scandinavia AB	Climeon AB	Isofol Medical AB	Surgical Science
Azelio	Egetis Therapeutics	Linkfire A/S	Swedencare AB
Bionvent	Implantica	LMK Group	Vicore Pharma
Biovica International	Green Landscaping Group AB	Media & Games Invest plc.	VNV Global
Cibus Nordic Real Estate AB	Hexicon	Re:NewCell	

Members of the Pareto Group provide market making or other liquidity providing services to the following companies included in Pareto Securities AB's research coverage universe:

Africa Energy Corp.	Logistri Fastighets AB	Minesto	Shamran Petroleum
ByggPartner i Dalarna Holding	Magnolia Bostad	Saltängen Property Invest	Surgical Science
Cibus Nordic Real Estate	Media & Games Invest plc.	SciBase Holding	Tethys Oil
Isofol Medical	Mentice AB	Sedana Medical	Vostok Emerging Finance

Members of the Pareto Group have entered into agreements concerning the inclusion of the company in question in Pareto Securities AB's research coverage universe with the following companies: None
Member of the Pareto Group is providing Business Management services to the following companies:

Bosjö Fastigheter AB	Bråviken Logistik	Halmslätten	Målaråsen
Bonäsudden	Delarka	Logistri	Sydsvenska Hem

Members of the Pareto Group have entered into agreements concerning the inclusion of the company in question in Pareto Securities AB's research coverage universe with the following companies: None
This overview is updated monthly (last updated 16.08.2021).

Appendix E

Disclosure requirements in accordance with Article 6(1)(c)(i) of Commission Delegated Regulation (EU) 2016/958

Designated Sponsor

Pareto Securities acts as a designated sponsor for the following companies, including the provision of bid and ask offers. Therefore, we regularly possess shares of the company in our proprietary trading books. Pareto Securities receives a commission from the company for the provision of the designated sponsor services.

2G Energy *	GFT Technologies *	Merkur Bank	SMT Scharf AG *
Biotest *	Gigaset *	MLP *	Surteco Group *
CORESTATE Capital Holding S.A.	Heidelberg Pharma *	mutares	Syzygy AG *
Daldrup & Söhne	Intershop Communications AG	OVH Holding AG	TAKKT AG
Demire	Leifheit	Procredit Holding *	Viscom *
Epigenomics AG*	Logwin *	PSI SOFTWARE AG *	
Gesco *	Manz AG *	PWO *	
Gerry Weber	MAX Automation SE	S&T AG *	

* The designated sponsor services include a contractually agreed provision of research services.

Appendix F

Disclosure requirements in accordance with Article 6(1)(c)(iv) of Commission Delegated Regulation (EU) 2016/958

Sponsored Research

Pareto Securities has entered into an agreement with these companies about the preparation of research reports and—in return—receives compensation.

Adler Modemaerkte	Dermapharm Holding SE	Intershop Communications AG	mutares
Baywa	Enapter	Leifheit	OHB SE
BB Biotech	Expres2ion Biotechnologies	MAX Automation SE	OVH Holding AG
CLIQ Digital	Gerry Weber	Merkur Bank	Siegfried Holding AG
Daldrup & Söhne	Hypoport AG	Mynarc	

This overview is updated monthly (last updated 16.08.2021).